

welding & safety





An Indo Malaysian
Joint Venture

WORLD CLASS WELDING & CUTTING EQUIPMENTS



Years of
Manufacturing
Excellence



**SALES
SERVICE
SKILLING..**

wimindia.com



DO THE WELDING. FEEL THE DIFFERENCE....

CWIM-To be the customers' preferred brand choice, providing Total Welding Solutions with excellent after sales support.

The Story-1972:

Founded by seven Leong brothers, Welding Industries Malaysia (WIM) is a global manufacturer of World Class Welding and Cutting Equipments.

WIM India is an Indo Malaysian Joint Venture between Welding Industries Malaysia Sdn. Bhd and Centroid Group, India. It is a part of a Rs. 1500 Million (USD 20 Million) industrial conglomerate with over five decades of proven track record in the engineering industry. Our rich experience in Manufacturing, Marketing and Service management enable us to provide our customers thoroughly researched, tested and customised solutions that meet their specific requirements. Our specialist engineers and technologists are actively involved in the development of user-friendly, reliable and industry-specific products.

As a leader and prime manufacturer in the field of welding products, it has an on-going commitment to produce high quality products and offer excellent services. **WIM** won the Best Product Award 2003 given by trade organization Small and Medium Industries of Malaysia .

About 70 per cent of more than 60 models of Welding Machines, particularly key parts like transformers and PCBs are manufactured in house. **CENX WIM** range of products include MMA, GMAW, GTAW, Spot Welding, Plasma Cutting, Plasma Welding and Robotic Automation.

Embracing exports and localizing the product to all corner of the globe, global marketing represents a substantial proportion of the turnover. Sustained market penetration into export markets promises continuous development of **CENX WIM** business worldwide.

CENX WIM will be broadening its product range to include high-technology welding machines to cater to the developed countries. Our commitment to originality and innovative-technology ensures that growth to date will be more than matched by future achievements.

With a global presence, a growing portfolio of products and services and an impressive list of clientele we are always ready for a new future, a future that will expand our operations, extend our international reach and bring us exponential growth.

CENX WIM also provides excellent after-sales support and are into Skill Development - training to technicians of customers and students.

Our Vision

To be a respected world-class organisation and the most respected company in the field of Welding in terms of quality, productivity and customer satisfaction.

Our Credo

- Building lasting relationships with customers based on trust and commitment
- Upholding highest ethical standards in conduct of business
- Creating and nurturing the spirit of innovation
- Making a meaningful contribution to the society

The Team

Clear vision, a sense of dedication and purpose, roll-up-your-sleeves work ethics, willingness to walk the extra mile are few traits of **CENX WIM**. The promoters personify the true spirit of enterprise and have a burning passion to excel in whatever enterprise they venture into. Since its inception we have established a reputation that's envied by many. The management team is well supported by skilled and dedicated workforce. We are backed by specialist engineers and technologists who are actively involved in the design and development of innovative and industry specific products.

Each and every product of **CENX WIM**, bear the stamp of excellence.

CENX WIM always assures happy and safe welding.



ARC (MMA) INVERTERS - Economy Series



MMA 200E ***

PROFESSIONAL MACHINE

IGBT Inverter Technology; DC Output
Input: Single Phase; Wt. 4.5Kgs.
Electrode Usable: Upto MS 6013-3.15mm
Duty Cycle: 60%; Digital Display
Suitable for Scratch TIG



MMA 200 Classic***

PROFESSIONAL MACHINE

IGBT Inverter Technology; DC Output
Input: Single Phase; Wt. 4.5Kgs.
Electrode Usable: Upto MS 6013-3.15mm
Duty Cycle: 60%; Dual Fan
Suitable for Scratch TIG



MMA 200***

PROFESSIONAL MACHINE

IGBT Inverter Technology; DC Output
Input: Single Phase; Wt. 4.5Kgs.
Electrode Usable: Upto MS 6013-3.15mm
Duty Cycle: 60%; MCB Incorporated; Dual Fan
Suitable for Scratch TIG



MMA 200XP***

PRODUCTION MACHINE

IGBT Inverter Technology; DC Output
Input: Single Phase; Wt. 5.0Kgs.
Electrode Usable: Upto MS 6013-4.0mm
Duty Cycle: 60%; MCB Incorporated; Dual Fan
Digital Display & Suitable for Scratch TIG

INVERTERS-Euro Series



MMA 201E

PROFESSIONAL MACHINE

IGBT Inverter Technology; DC Output
Input: Single Phase; Wt. 4.5Kgs.
Electrode Usable: Upto MS 6013-3.15mm
Duty Cycle: 60%; Digital Display,
Suitable for Scratch TIG, Dual Colour Handle



MMA 201***

PRODUCTION MACHINE

IGBT Inverter Technology; DC Output
Input: Single Phase; Wt. 4.5Kgs.
Electrode Usable: Upto MS 6013-3.15mm
Duty Cycle: 60%
Suitable for Scratch TIG



MMA 201Xp***

PRODUCTION MACHINE

IGBT Inverter Technology; DC Output
Input: Single Phase; Wt. 6.5Kgs.
Electrode Usable: Upto MS 6013-4.0mm
Duty Cycle: 60%
Digital Display & Suitable for Scratch TIG



MMA IA 200SP

PRODUCTION MACHINE

IGBT Inverter Technology; DC Output
Input: Single Phase; Wt. 9.0Kgs.
Electrode Usable: Upto MS 6013-4.0mm
Duty Cycle: 60%; Can melt Al. Electrode
Suitable for Scratch TIG; Digital Display,



MMA 200D - Digital Control

PRODUCTION MACHINE

HEAVY DUTY - IGBT Technology
Input: Single Phase; DC Output
Electrode: Upto 3.15mm
Duty Cycle: 60%
Suitable for Scratch TIG



MMA 250 / 251

PRODUCTION MACHINE

IGBT Technology; DC Output
Input: Single Phase; Wt. 7.5Kgs.
Electrode Usable: Upto MS 6013-4.0mm
Duty Cycle: 60%; Suitable for Scratch TIG
MCB Incorporated in 251



MMA 400/401

PRODUCTION MACHINE

IGBT Inverter Technology; DC Output
Input: Three Phase; Wt. 17.0Kgs.
Electrode Usable: Upto MS 6013-4.0mm
Duty Cycle: 60%; MCB Incorporated
Suitable for Scratch TIG



MMA IA 300X/400X/500X

PRODUCTION MACHINE

IGBT Inverter Technology; DC Output
Input: Three Phase; Wt. 25.0Kgs.
Electrode Usable: Upto MS 6013-5.0mm
Duty Cycle: 60%; Can melt Al. Electrode
Suitable for Scratch TIG; Optional: Remote

RECTIFIERS-Euro Series



MMA IG 300H/400H/500H

PRODUCTION MACHINE

IGBT Inverter Technology; DC Output
Input: Three Phase; Wt. 45.0Kgs.
Electrode Usable: Upto MS 6013-3.15-5.0mm
Duty Cycle: 60%; Can melt Al. Electrode
Suitable for Scratch TIG; Optional: Remote



RX 400/500/600

PRODUCTION MACHINE

Thyristor Controlled; DC Output
Input: Three Phase; Wt. 183.0Kgs.
Electrode Usable: Upto MS 6013-5.0mm
Duty Cycle: 60%; Suitable for Scratch TIG
RX600 for Gouging



ER 300

PRODUCTION MACHINE

Silicon Rectifier Technology; DC Output
Input: Three Phase; Wt. 110.0Kgs.
Electrode Usable: Upto MS 6013-3.15-5.0mm
Duty Cycle: 60%
Suitable for Scratch TIG

International Series



TS 300/400/600

PRODUCTION MACHINE

HEAVY DUTY - Rectifier
Input: Three Phase
Electrode: Upto 6.0mm, Duty Cycle: 60%
Suitable for Gouging



ARC (MMA)
TRANSFORMERS - International Series



MH 135
PORTABLE - LIGHT DUTY
Input : Single Phase; Wt. 28.0 Kgs.
Electrode : Upto 3.15mm
Duty Cycle : 35%
Two Years Warranty for Transformer



AC 200A
HEAVY DUTY - MOVING CORE
Input: Single / Two Phase
Electrode: Upto 3.15mm
Duty Cycle: 40%
Two Years Warranty for Transformer



AC 300A / AC 400A
HEAVY DUTY - MOVING CORE
Input: Two Phase
Electrode: Upto 5.0mm
Duty Cycle: 40%
Two Years Warranty for Transformer



AC 500A
HEAVY DUTY - MOVING CORE
Input: Two Phase
Electrode: Upto 6.00mm & Special
Duty Cycle: 60%
Two Years Warranty for Transformer



MIG/MAG (GMAW)
INVERTERS - Euro Series



MIG/MAG 200
PROFESSIONAL MACHINE
IGBT Inverter Technology; DC Output
Input: Single Phase; Wt. 27.0Kgs.
Built in Closed Wire Feeder
Duty Cycle: 60%
Suitable for Aluminium Welding



MIG/MAG 270
PRODUCTION MACHINE
IGBT Inverter Technology; DC Output
Input: Three Phase; Wt. 28.0Kgs.
Built in Closed Wire Feeder
Duty Cycle: 60%; MMA Possible
Electrode Usable: Upto MS 6013-3.15mm
Suitable for Aluminium Welding



MIG/MAG 400
PRODUCTION MACHINE
IGBT Inverter Technology; DC Output
Input: Three Phase; Wt. 30.0Kgs.
External 4 Roller Wire Feeder
Duty Cycle: 60%; MMA Possible
Electrode Usable: Upto MS 6013-4.0mm
Suitable for Aluminium Welding



MIG/MAG 500 / 630N (HD)
PRODUCTION MACHINE
IGBT Inverter Technology; DC Output
Input: Three Phase; Wire Dia: upto 3.0mm
External 4 Roller Wire Feeder
Duty Cycle: 60%; MMA Possible
Electrode Usable: Upto MS 6013-5.0mm
Suitable for Aluminium Welding

INVERTERS - International Series



IM 201
MAINTENANCE MACHINE
Input: Single Phase; Wt. 20.0 Kgs
Wire Feeder: Inbuilt
Wire Ø: 0.6mm to 1.0mm
Suitable for Aluminium Welding



IM 273G
PRODUCTION MACHINE
Input: Three Phase; Wt. 170.0 Kgs
Wire Feeder: Inbuilt
Wire Ø: 0.6mm to 1.2mm
Suitable for Aluminium Welding



IMG 400F / 500F
PRODUCTION MACHINE
Input: Three Phase
Wire Feeder: External
Wire Ø: 0.6mm to 1.6mm & Flux Cored
Suitable for Aluminium Welding

Thyristor



TA 401i / 501i
PRODUCTION MACHINE
Input: Three Phase
Wire Feeder: External
Wire Ø: 0.6mm to 1.6mm & Flux Cored
Suitable for Aluminium Welding

Tapping Switch



MIG 210
PRODUCTION MACHINE
Input: Single Phase; Wt. 72.0 Kgs
Wire Feeder: Internal/External (SEF)
Wire Ø: 0.6mm to 1.0mm
Suitable for Aluminium Welding



MIG ES 273
PRODUCTION MACHINE
Input: Three Phase; Wt. 97.0 Kgs
Wire Feeder: Internal
Wire Ø: 0.6mm to 1.2mm
Suitable for Aluminium Welding



MIG 280 S
PRODUCTION MACHINE
Input: Three Phase; Wt. 125.0 Kgs
Wire Feeder: Internal/External (SEF)
Wire Ø: 0.6mm to 1.2mm
Suitable for Aluminium Welding



MIG 400 SEF / 500 SEF
PRODUCTION MACHINE
Input: Three Phase; Wt. 170.0 Kgs
Wire Feeder: External
Wire Ø: 0.6mm to 1.6mm & Flux Cored
Suitable for Aluminium Welding



TIG/MMA (GTAW) INVERTERS - Euro Series



ITG 200
PROFESSIONAL MACHINE
IGBT Inverter Technology; DC Output
Input: Single Phase; Wt. 7.0Kgs.
Inbuilt HF, Duty Cycle: 60%;
Electrode Usable: Upto MS 6013-3.15mm



ITG 300
PRODUCTION MACHINE
IGBT Inverter Technology; DC Output
Input: Three Phase; Wt. 28.0Kgs.
Inbuilt HF, Duty Cycle: 60%;
Electrode Usable: Upto MS 6013-4.0mm



ITG 400
PRODUCTION MACHINE
IGBT Inverter Technology; DC Output
Input: Three Phase; Wt. 28.0Kgs.
Inbuilt HF, Duty Cycle: 60%;
Electrode Usable: Upto MS 6013-5.0mm



ITG 200P
PRODUCTION MACHINE
IGBT Inverter Technology; DC Output
Input: Single Phase; Wt. 15.0Kgs.
Inbuilt HF & Pulse Control
Duty Cycle: 60%;



Plasma Cutting INVERTERS - Euro Series



IPS 40
PROFESSIONAL MACHINE
IGBT Inverter Technology
Input: Single Phase; Wt. 11.0Kgs.
Touch Start & Air Pressure: 6.0 Bar
Duty Cycle: 60%;
Maximum Cutting Thickness: MS 12.0mm



IPS 60
PRODUCTION MACHINE
IGBT Inverter Technology
Input: Single Phase; Wt. 19.0Kgs.
Inbuilt HF & Air Pressure: 6.0 Bar
Duty Cycle: 60%;
Maximum Cutting Thickness: MS 20.0mm



IPS 100
PRODUCTION MACHINE
IGBT Inverter Technology
Input: Three Phase; Wt. 25.0Kgs.
Inbuilt HF & Air Pressure: 6.0 Bar
Duty Cycle: 60%;
Maximum Cutting Thickness: MS 35.0mm



ITG 300P AC/DC
PRODUCTION MACHINE
IGBT Inverter Technology; AC/DC Output
Input: Three Phase; Wt. 55.0Kgs.
HF & Pulse Control, Duty Cycle: 60%;
Suitable for Aluminium Welding
Electrode Usable: Upto MS 6013-3.15mm



Spot Welders PEDAL - Economy Series



CSW4
PROFESSIONAL MACHINE
Input: Single Phase
Excellent Cooling System
Adjustable Pedal
Max. Thickness: 1.0mm



CSW10/15/25
PRODUCTION MACHINE
Input: Two Phase
Excellent Cooling System
Adjustable Pedal
Max. Thickness: 2.0-5.0mm

Portable



MC 8
HAND HELD PRODUCTION MACHINE
Input: Single Phase; Wt. 37.0Kgs.
Max. Thickness: 1.6mm
Hand Gun & Clamp Gun



Diesel Engine Welder



ALPHA WELD 500 D
Output : 500 Amps-DC
Engine : Deutz
Generator : 30 Kva



Multi Process (MMA, MIG & TIG) INVERTERS - International Series



MULTI 350/450/550
PRODUCTION MACHINE
Input: Three Phase; DC Output
Electrode Usable: Upto MS 6013-6.0mm
Wire Dia: 0.6mm to 1.6mm and Flux Cored
Duty Cycle: 100%, Wt. 55.0Kgs.

Optional Attachments:
MIG Wire Feeder
& TIG-DC HF



EVO 500
PRODUCTION MACHINE
Input: Three Phase; DC Output
Electrode Usable: Upto MS 6013-5.0mm
Constant Current-ARC/MIG/TIG
Duty Cycle: 70%, Wt. 70.0Kgs.



Multi Operator



WELD MASTER
WELD PLUS 1600/2400/3000
Input: Three Phase
Duty Cycle : 70%



Submerged Arc



SAW 1250i
Output : 200-1000 Amps-DC
Duty Cycle : 60%
Wire Ø : 1.6-6.0mm



ARC (MMA) TRANSFORMERS - Economy Series



Spot & Projection PNEUMATIC - International Series



TX 200/250/300
PROFESSIONAL MACHINE-SS Body
Transformer Technology; AC Output
Input: Single Phase; Wt. 20.0Kgs.
Electrode Usable: Upto MS 6013-3.15-5.0mm
Duty Cycle: 60%



TXi200/300/400/500/600
PRODUCTION MACHINE
Transformer Technology; AC Output
Input: Single Phase; Wt. 20.0Kgs.
Electrode Usable: Upto MS 6013-3.15mm
Moving Core; Duty Cycle: 60%



JPC 35/50
Input: Two Phase;
Sheet Thickness upto : 10.0mm



JPC 75/100
Input: Two Phase;
Sheet Thickness upto : 20.0mm



Automation TURN TABLE

SPM's



T 60
Load : Max 60 Kgs
RPM : 0-33, Angle : 0-90°

Welding Rotator



Column and Boom Welding Manipulators



Wiremesh Welding System



Optional Accessories



TTCS 10/20
TIG Torch Cooling System



DC 500 HF
High Frequency Unit



Asian Wire Feeder
MIG Wire Feeder



Euro Wire Feeder
MIG Wire Feeder



Genuine Accessories



Our Training Facility

WIM & GTTI: Imparting 100 years of acquired knowledge

Late Shri G.D.Naidu, was a successful industrialist, a keen educationalist, philanthropist and a great innovator of South India. In 1946, he started an institute in the name of Industrial Labour Welfare Association (ILWA), now known as G.D.Naidu Charities. His aim was to impart higher education with more emphasis on practical training so that students can get employment immediately.

Gedee Technical Training Institute (GTTI), unit of G.D Naidu Charities, in association with IHK Nurenberg, Germany, has been conducting courses on Precision Machining Technology, Tool and Die Engineering, Mechatronics and advanced course in Tool design and Mechatronics. Other than this G.D. Naidu charities is conducting short term courses on Automobile Service and Maintenance in association with Volkswagen, Pune, and various other short term courses such as EDM, CMM, CAD (Autocad, Pro-E, Inventor, Power Shape, CATIA, ANSYS, SOLID WORKS, etc), CAM(Keller, Delcam, Unigraphics), Metrology, CMM, etc. It has trained more than 50,000 Students over the past 6 decades.

WIM is proud to be associated with GTTI.

GEDEE WIM offers various long and short term courses in Welding approved by Indian Institute of Welding (IIW). Our commitment to the society and its requirements has led us to undertake this mission of providing quality welding training. **WIM** is the official Welding Training provider for the GIATMARA Scheme of Government of Malaysia. Our Mission is "to enhance the skill set of a person, enable them to perform at the best in their jobs and career thereby contribute to the overall growth of the industry"

Our Infrastructure



Manufacturing Head Quarters, Malaysia



Automatic Production Line



Assembly Line



State of the art testing facility

An ISO certified factory with a total built up area of about 45,000 Sq. mm and a team of 300 strong dedicated workforce **WIM** manufactures a range of Welding and Cutting Equipments. State of the art R & D Centre, in house facility for cutting, welding, assembling and powder coating are the real strength of **WIM**. **WIM** products confirms to CCC, CE, GS and RoHS standards. Currently **WIM** products are exported to over 50 Countries in the Asia, Africa, America, Middle East, and European markets.

Advantages of WIM

INTERNATIONAL RECOGNITION



Latest Technology



Heavy Duty



Low Power Consumption



User Friendly



Reliable after Sales Service



Economically Priced



One Year Warranty



WIM Service

- State of the Art Service Centre
- Machines serviced by qualified and trained Engineers
- Component level PCB servicing performed
- Adequate stock of Spares and Accessories

*** ONE YEAR WARRANTY - CARRY IN SERVICE

Our Training Facility

Gedee-WIM Institute of Welding Technology (A Unit of G D Naidu Charities)

Approved By The Indian Institute Of Welding (IIW)

734, Avinashi Road, Coimbatore-641 018, Tamil Nadu, **India.**

Tel : +91 422 2222 243, Mobile : +91 94438 43261,

Fax : +91 422 2242 760

Email: info@gedeewim.in; www.gedeewim.in

R&D being a continuous process, specifications are subject to change without prior notice.



WIM India Private Limited

(An Indo Malaysian Joint Venture)

380, Dr. Nanjappa Road, Coimbatore-641 018, India.

T : +91 422 438 0081, 438 0082

E : info@wimindia.com, www.wimindia.com

Manufacturing Head Quarters

Welding Industries (M) Sdn. Bhd.

31550 Pusing, Perak Darul Ridzuan, Malaysia.

T : +60 5 366 8828

E : wim@wim.com.my, www.wim.com.my

an universe of welding accessories





welspring.com



centroid.in

A Universe of Welding Accessories

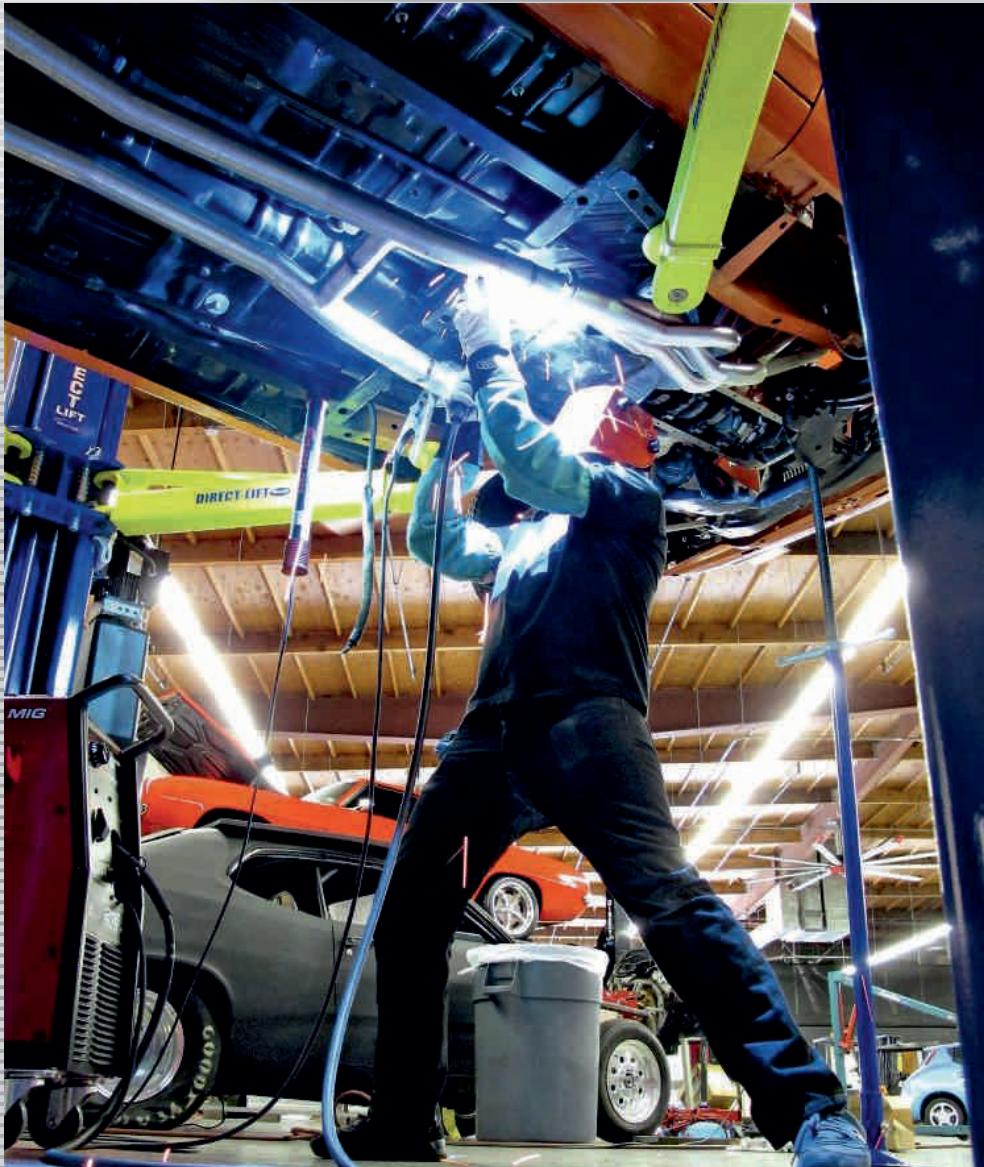

Manufacturing Facility, India



Quality Standards



CERTIFICATE



This is to certify that

Welspring Universal
43 KM Milestone, NH-10
Delhi-Rohitak Road, Village- Mandoshi & Asauda
PO- Asauda, Bahadurgarh- 124-507
Haryana
INDIA

has implemented and maintains a **Quality Management System**.

Scope:
Design and Manufacture of Welding Accessories.

Through an audit, documented in a report, it was verified that the management system fulfills the requirements of the following standard:

ISO 9001 : 2008

Certificate registration no.	20003527 QM08
Date of original certification	2000-07-13
Date of certification	2016-07-13
Valid until	2018-09-14



DQS Inc.
Janesh Raw
Janesh Raw
Managing Director

Accredited Body: DQS Inc., 1130 West Lake Cook Road, Suite 340, Buffalo Grove, IL 60089 USA
Administrative Office: Deutsch Quality Systems (India) PVE Ltd., 9th Floor, Arjuneya Techno Park,
167, 16th Avenue Road, Kothavali, Bangalore - 560 077 - India













As the oldest and most reputed manufacturer of manual arc welding accessories in India, we owe it to our customers to certify the quality of our products.

All our welding products are regularly tested for electrical, thermal & mechanical properties, at our fully equipped, in- house laboratory.

A certificate of quality assurance can be issued (upon request) for all our products that conform to the quality standards stated below:

All products marked **CE** conform to European standards as published by CENELEC (European Committee for Electro Mechanical Standardization), and British Standards Institute. Other products that conform to the various standards are also marked accordingly.

- | | |
|-----------------------|--|
| EN-60974-11 | : for Electrode Holders |
| EN-60974-12 | : for Cable Connectors & Panel Plugs & Sockets |
| EN-60974-13 + BS638.5 | : for Earth Clamps |
| EN-60974-7 | : for Mig Torches |
| EN-60974-1 | : for Electrode Heating Quivers/Ovens |
| EN-175 | : for Head & Hand Screens |
| EN-166/169 | : for Welding Filters & Lenses |
| EN-379 | : for Auto Darkening Filters |
| EN-20598 | : for Welding Curtains |
| EN-470-1 | : for Flame Retardant Apparel |

EXPLANATION OF SYMBOLS					
 Amp Rating	 Cable Size	 Electrode Size	 Main Conductor Alloy	 Electrode Capacity	 Temperature Range
 Length	 Diameter	 Net Weight	 Individual Printed Box	 Individual White Box	 Minimum Pack Quantity

Disclaimer Notice :
Due to continuous product improvement, dimensions, size, weight and other specifications may change from time to time, based on product research & customer feedback. Any such changes would be implemented without prior notice.



Electrode Holders

Economy Series EHAL20 GF Polyamide Handle	Economy Series EHHB20 GF Polyamide Handle	Economy Series EHDMT20 GF Polyamide Handle	Economy Series EHMS40 Thermoset Handle
Economy Series EHMS60 Thermoset Handle	Handy Cool Type EHHC40 Thermoset Handle	Handy Cool Type EHHC60 Thermoset Handle	Economy Series EHECO40 GF Polyamide Handle
Economy Series EHECO20 GF Polyamide Handle	Economy Series EHES6035 GF Polyamide Handle	Economy Series EHTW3025S GF Polyamide Handle	Economy Series EHL6035 GF Polyamide Handle
Economy Series EHECO20 GF Polyamide Handle	Economy Series EHES6035 GF Polyamide Handle	Economy Series EHTW3025S GF Polyamide Handle	American Series EHL6035 GF Polyamide Handle

Earth Clamps

Croco Series ECCR20 without insulation ECCR20i with insulation • With Braided Copper Shunt • Steel Jaws • Steel Stud, Bolt #3 25mm ² 100 Pcs	Croco Series ECCR40S without insulation ECCR40Si with insulation • Without Copper Shunt • Steel Jaws • Steel Stud, Bolt #4 50mm ² 50 Pcs	Croco Series ECCR40 without insulation ECCR40i with insulation • With Braided Copper Shunt • Brass Jaws • Steel Stud, Bolt #4 70mm ² 50 Pcs	Euro-Brass Series ECGM40 No Copper Shunt ECGM40C With Copper Shunt EN-60974-13	Euro-Brass Series ECGM20 No Copper Shunt ECGM20C With Copper Shunt EN-60974-13
---	---	--	--	--

Cable Connectors

Euro Style CCD1025F Euro Style CCD1025M	Euro Style CCD3550F Euro Style CCD3550M	Euro Style CCD5070F Euro Style CCD5070M	Euro Style CCD7095F Euro Style CCD7095M	Euro Style CCL3550F Euro Style CCL3550M	Euro Style CCL5070F Euro Style CCL5070M	Euro Style CCL7095F Euro Style CCL7095M
---	---	---	---	---	---	---

Cable Lugs & Splicers

TER7 Connect with American Male Connector MBP or LC40 without sleeve with sleeve	CLSO168 Tinned Copper Lug 	CLSO5010 Tinned Copper Lug 	CLSO258 Tinned Copper Lug 	CSSO7095 Tinned Copper Lug 	MICRIMP Crimping Tool Used for affixing cable into a cable lug. Hit punch head with hammer to crimp cable into lug.
--	---	--	---	--	--

Machine Couplings

Machine Panel Socket MCLC10F Connect with American LC10 or 1MBP Plug CE	Machine Panel Socket MCLC40F Connect with American LC40 or 2MBP Plug CE	Machine Panel Socket MC1025F Machine Panel Plug MC1025M	Machine Panel Socket MC3550F Machine Panel Plug MC3550M	Machine Panel Socket MC1025L Attach cable here 10mm Hole ID CE	Machine Panel Socket MC3595LX Attach cable here 10mm Hole ID CE
--	--	---	---	--	---

Ground & Rotary Ground Clamps

C Clamp



C-CLAMPS					
MODEL	Len Clamping	Thread	Spindle Dia	Max Height	Weight Pcs
CLMP402	0-2"	3.25"	9/16"	0.4 Kg	20 Pcs
CLMP404	0-4"	3.25"	3/4"	1.5 Kg	10 Pcs
CLMP406	0-6"	4.00"	3/4"	2.3 Kg	10 Pcs
CLMP408	0-8"	5.00"	3/4"	2.9 Kg	5 Pcs
CLMP410	0-10"	6.00"	3/4"	4.7 Kg	5 Pcs
CLMP412	3-12"	6.30"	7/8"	6.7 Kg	5 Pcs

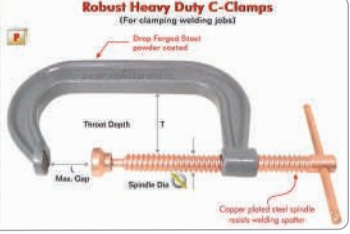

MIG Torches

MT15AK
16mm² cable
Length: 3m, 4m, 5m

insulated swan neck
other grip types & colours available see 15a, 15b 15c below

CE
EN 60974-7

W
5 Pcs

A
35% : 250 Amp
60% : 200 Amp
100% : 180 Amp

MT25AK
25mm² cable
Length: 3m, 4m, 5m

other grip types & colours available see 15a, 15b 15c below

CE
EN 60974-7

W
5 Pcs

A
35% : 350 Amp
60% : 300 Amp
100% : 200 Amp

MT24KD
25mm² cable
Length: 3m, 4m, 5m

other grip types & colours available see 15a, 15b 15c below

CE
EN 60974-7

W
5 Pcs

A
35% : 350 Amp
60% : 300 Amp
100% : 250 Amp

MT36KD
50mm² cable
Length: 3m, 4m, 5m

other grip types & colours available see 15a, 15b 15c below

CE
EN 60974-7

W
5 Pcs

A
35% : 500 Amp
60% : 400 Amp
100% : 360 Amp

MT40KD
60mm² cable
Length: 3m, 4m, 5m

other grip types & colours available see 15a, 15b 15c below

CE
EN 60974-7

W
5 Pcs

A
35% : 500 Amp
60% : 450 Amp
100% : 400 Amp

MT40KDi
60mm² cable
Length: 3m, 4m, 5m

insulated swan neck
other grip types & colours available see 15a, 15b 15c below

CE
EN 60974-7

W
5 Pcs

A
35% : 500 Amp
60% : 450 Amp
100% : 400 Amp

Optional Handle
all Models also available in these handle types

15 a 15 b 15 c 15 d shown above

Gouging Torches

GTK3 500-600 Amp  TESTED TO EN 60974-7

Gouging Torch

Standard : 5/8" internal thread

Optional : 3/8" internal thread



Standard Cable : 7ft (2.1m)
Optional Cable : 10ft (3m)



GTK3K 500-600 Amp  TESTED TO EN 60974-7

Gouging Torch

Standard : 5/8" internal thread

Optional : 3/8" internal thread

Angled head



Standard Cable : 7ft (2.1m)
Optional Cable : 10ft (3m)



GTK4 800-1000 Amp  TESTED TO EN 60974-7

Gouging Torch

Standard : 5/8" internal thread

Optional : 3/8" internal thread



Standard Cable : 7ft (2.1m)
Optional Cable : 10ft (3m)



GTK4K 800-1000 Amp  TESTED TO EN 60974-7

Gouging Torch

Standard : 5/8" internal thread

Optional : 3/8" internal thread

Angled head



Standard Cable : 7ft (2.1m)
Optional Cable : 10ft (3m)



GTK5 1000-1200 Amp  TESTED TO EN 60974-7

Gouging Torch

Standard : 5/8" internal thread

Optional : 3/8" internal thread



Standard Cable : 7ft (2.1m)
Optional Cable : 10ft (3m)



GTK5K 1000-1200 Amp  TESTED TO EN 60974-7

Gouging Torch

Standard : 5/8" internal thread

Optional : 3/8" internal thread

Angled head



Standard Cable : 7ft (2.1m)
Optional Cable : 10ft (3m)



Chipping Hammers

Euro-Series CHSHET
English Type



American Series CHSHH
Cone & Chisel with Spring Handle

Cone



Chisel

Euro-Series CHRGL
Red Grip Large



American Series CH7002
Cone & Chisel Head

Red Grip



Chrome Plated

Tank Wrenches

TW10X
Tank Wrench 10X for Acetylene Cylinders



9/32"

TW20
Tank Wrench 20 for Commercial Cylinders



3/8"

Welding Helmets, Hand Shields, Spare Windows & Head Gear

T-Type Thermoplastic 

Available in 5 Window Sizes (see below)



Removable Lift Open Window Slide on & off

510 gms

20 Pcs

* Dark Glass & Cover Plate Are Not Part of The Standard Model

WH-HDGRB



Push turn knob

50 Pcs

Spare Window
Size: 3 1/2 x 4 1/2" (83 x 108mm)



100 Pcs

A-Type Thermoplastic 



272 gms

30 Pcs

* Dark Glass & Cover Plate Are Not Part of The Standard Model

Glasses & Cover Plates

Dark Glass
Welding Dark Glass 

- Thickness : 3.0 mm
- Shades : 9-13
- Size available : see table below

Model	Glass size	Packing
WH-GL2414	2 x 4 1/2" (51 x 108 mm)	1000 Pcs
WH-GL314414	3 1/2 x 4 1/2" (83 x 108 mm)	600 Pcs
WH-GL412514	4 1/2 x 5 1/2" (114 x 133 mm)	200 Pcs
WH-GL7598	75 x 98 mm	600 Pcs
WH-GL90110	90 x 110 mm	400 Pcs
WH-GL100120	100 x 120 mm	400 Pcs
WH-GL50R5	50 mm Round	1000 Pcs

Cover Plate
Poly Carbonate 

- Thickness : 1.0 mm standard
2.0 mm also available
- Shatter Resistant
- Other sizes available upon request

Model	Glass size	Packing
WH-CP2414	2 x 4 1/2" (51 x 108 mm)	1000 Pcs
WH-CP314414	3 1/2 x 4 1/2" (83 x 108 mm)	1000 Pcs
WH-CP412514	4 1/2 x 5 1/2" (114 x 133 mm)	1000 Pcs
WH-CP7598	75 x 98 mm	1000 Pcs
WH-CP90110	90 x 110 mm	1000 Pcs
WH-CP100120	100 x 120 mm	1000 Pcs

Auto Darkening Helmets

Auto Darkening
WH-ADW913
Fiberglass

Fiberglass Shell

586 gms
6 Pcs
W

Auto Darkening
WH-ADC
Thermoplastic

CE

513 gms
6 Pcs
W

Auto Darkening
WH-AD777
Thermoplastic

CE

460 gms
6 Pcs
W

New

Goggles

WG2414LF
Welding Goggle

• 2 x 4 1/4" lens
• Lift front

50 Pcs

SG100M
Safety Goggle

CE ANSI

• Polycarbonate Lens
• Scratch Resistant
• Ventilated frame

100 Pcs

SS1000LIGHT
Safety Spectacle

CE ANSI

• Polycarbonate Lens
• Scratch Resistant

120 Pcs

SS1936CLEAR
Safety Spectacle

CE ANSI

• Polycarbonate Lens
• Scratch Resistant
• Adjustable length ear piece

120 Pcs

WG50LF
Welding Goggle

• Lift front cup goggle
• Soft PVC frame
• 50mm lens

50 Pcs

SG600LW
Safety Goggle

CE ANSI

• Polycarbonate Lens
• Scratch Resistant
• Ventilated frame

100 Pcs

SS1000DARK
Safety Spectacle

CE ANSI

• Polycarbonate Lens
• Scratch Resistant

120 Pcs

SS1936DARK
Safety Spectacle

CE ANSI

• Polycarbonate Lens
• Scratch Resistant
• Adjustable length ear piece

120 Pcs

Leather Gloves

SPLG1
Light Duty Leather Gloves

Length = 13"
Width @ Opening = 5 3/4"
Net Weight = 190 gms

100 Pair

CE

SPLG2
Welder's Leather Gloves

Length = 10"
Width @ Opening = 5 1/2"
Net Weight = 170 gms

100 Pair

CE

SPLGTIG
Welder's Leather Gloves

Length = 13"
Width @ Opening = 6 1/2"
Net Weight = 160 gms

160 Pair

CE

SPLGR
Premium Leather Gloves

Length = 13"
Width @ Opening = 6 1/2"
Net Weight = 235 gms

50 Pair

CE

Wire Brushes

BRHSS4W
4 x 16 SS Wire Rows & Wooden Handle

Stainless Steel SS Wires

L = 290 mm
W = 30 mm
H = 15 mm

120 Pcs

BRHMS4W
4 x 16 MS Wire Rows & Wooden Handle

Mild Steel (MS) Wires

L = 290 mm
W = 30 mm
H = 15 mm

120 Pcs

BRHMS2W
2 x 14 MS Wire Rows & Wooden Handle

Mild Steel (MS) Wires

L = 290 mm
W = 25 mm
H = 15 mm

120 Pcs

BRHSSXM
Steel Wires Zn Plated

BRHSTXM
Steel Wires (Zinc Plated)

120 Pcs

Welding Blankets

FIBERGLASS UNCOATED							
Temp. Range: 600°C / 1100°F							
Approx. Thickness	Fabric Wt. g/m ² / oz/yd ²	Fabric Roll 50m x 1m or 2m / 164ft x 3.3ft or 6.5ft	1m x 1m Welding Blanket	2m x 1m Welding Blanket	2m x 2m Welding Blanket		
0.4mm	430 / 12.7	SPFGU1504	SPWBFG114	SPWBFG214	----		
0.8mm	820 / 24.2	SPFGU1508	SPWBFG118	SPWBFG218	----		
0.8mm	820 / 24.2	SPFGU2508	----	----	SPWBFG228		
1.5mm	1050 / 31.0	SPFGU15015	SPWBFG1115	SPWBFG2115	----		

Welding Curtains

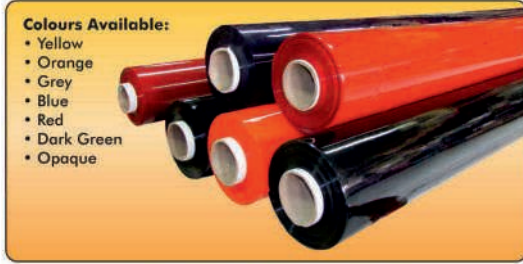

UNMACHINED FULL ROLLS

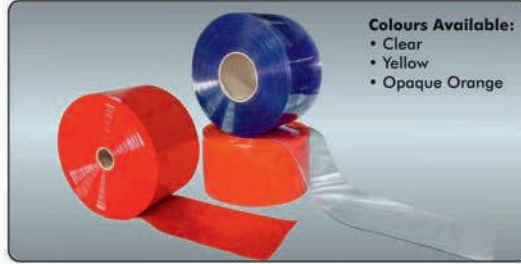

PVC STRIP ROLLS

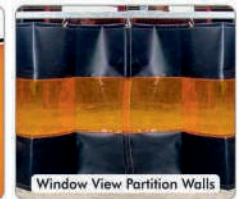

Pipe Stands & Welding Tables

PIPE STANDS S-TYPE COMPATIBLE (FOLDING) MODELS

PSHJV18S
Pipe Stand S-Type Hi-J

High Position: 50" (1,270mm)
Lo Position: 28.5" (730mm)

LOAD CAPACITY
2500Lbs / 1135kg

Box Size: 7 1/2" x 8 1/2" x 24" (197 x 222 x 610mm)
575 Pcs

PSLJV18S
Pipe Stand S-Type Lo-J

High Position: 35.5" (900mm)
Lo Position: 20.5" (520mm)

LOAD CAPACITY
2500Lbs / 1135kg

Box Size: 7 1/2" x 8 1/2" x 25" (197 x 222 x 635mm)
790 Pcs

PSHBV18HB
Pipe Stand S-Type HB

High Position: 72" (1825mm)
Lo Position: 39" (990mm)

LOAD CAPACITY
2500Lbs / 1135kg

Box Size: 9 1/2" x 10 1/2" x 44" (235 x 260 x 1124mm)
465 Pcs

Folding Models with Collapsible Legs

V-Head model PS-VH18S in supplied as standard

- 1 V-Head compatible with Summer Pipe Stands
- 2 T-Handle for Extra Safety in Securing V-Head
- 3 Handle to lift Pipe Stands
- 4 1" (25mm) Square Section Legs

ROLLER HEADS Available For All Models
Various Roller & V-heads options available

MIWT402436V2
Portable Foldable Welding Table

LOAD CAPACITY
180kg / 400Lbs

30mm hole on 4 corners to hold Mig Torch

Features

- Galvanized 14G steel sheet table top
- Table Dimension: 40" (L) x 24" (W) (100x60cm)
- Folding legs
- Load capacity: 180kg (400Lbs)
- 2 Pc x 6" wheel kit (Optional)
- Colour: Black, Yellow or Blue
- Ship Weight: 31kg (68 Lbs)

Wheel kit available MIWT40W6
includes:
• 6" wheel x 2pcs
• Axle Rod
• Hardware

Weight: 31kg (68Lbs)
Box Size: 45" x 25 1/2" x 4 1/4"

Cylinder Trolley

CyT6SH
Cylinder Trolley Double Cylinder
6" (150mm) wheels

Max Cylinder Dia: 7 1/2" (190mm)

LOAD CAPACITY
100 Kg / 220 Lbs

Box Size: 15 3/4" (400mm) x 8" (200mm)

CyT8SH
Cylinder Trolley Double Cylinder
8" (200mm) wheels

Max Cylinder Dia: 7 1/2" (190mm)

LOAD CAPACITY
100 Kg / 220 Lbs

Box Size: 19 1/2" (495mm) x 8" (200mm)

CyT8CH
Cylinder Trolley Double Cylinder
8" (200mm) wheels

Max Cylinder Dia: 9" (240mm)

LOAD CAPACITY
130 Kg / 285 Lbs

Box Size: 18 1/2" (470mm) x 10" (255mm)

CyT14CH
Cylinder Trolley Double Cylinder
1 1/4" (355mm) wheels

Max Cylinder Dia: 12 1/2" (315mm)

LOAD CAPACITY
200 Kg / 440 Lbs

Box Size: 25" (635mm) x 13" (330mm)

Electrode & Flux Ovens

MIG Cart

EQ20S3
10kg, 300°C

Electrode Capacity
10 kg / 22lbs

Temp. Range
300°C Max.

EQ10S **EQ10SD**
5kg, 150°C **1 2** 5kg, 150°C
Dual Voltage

Open View
Inner basket with hook

Electrode Capacity
5 kg / 10lbs

Temp. Range
150°C Max.

Dual Voltage 110V & 240V
option available

MIMCF
Mig Welding Cart-Standard

LOAD CAPACITY
200Lbs / 90Kg

20ft
15.8 Kft
980 Pcs

MIMC
Mig Welding Cart-Standard

LOAD CAPACITY
200Lbs / 90Kg

20ft
13.8 Kft
1250 Pcs

Miscellaneous Products

MISLE
Spark Lighter - Eco

250 Pcs

Extra Flints
MISLX5
Pack of 5

MISLSQ
Spark Lighter-Square Cup

250 Pcs

Extra Flints
MISLX5
Pack of 5

MISLPISTO
Spark Lighter Pisto Type

250 Pcs

Extra Flints
MISLX1
Singel Flint

MITC813
Tip cleaner Set-8 cm
Cleaner size 6-26
Drill size 77-49

500 Pcs

MITC1012
Tip cleaner Set-10 cm
Cleaner size 7-26
Drill size 75-49

500 Pcs

MITC1213
Tip cleaner Set-12 cm
Cleaner size 6-26
Drill size 77-49

500 Pcs

CLEANER SIZE	DRILL SIZE
6	77-76
7	75-74
8	73-71
10	70-68
12	67-65
14	64-62
15	61-60
16	59-58
17	57
18	56
22	53-54
24	53-52
26	51-49

MIMPLIER
Mig Plier

Blue grip also available

270 gms 50 Pcs

MIMPLIERDC
Mig Plier with Dual Color Grip

New

Application & Uses

- Spotter removal from inside and outside the nozzle
- Hammering
- Wire drawing
- Wire cutting
- Tip removal and installation
- Nozzle removal and installation
- Spring Loaded for easy opening and closing.

MIIMH2
Inspection Mirror
L = 16" (400mm)

Stainless Steel

Swivel Joint

50 Pcs

Magnetic Position Holders

Special features include:

- 4 Models to choose from depending on job weight & size;
- Can hold welding jobs (Sheet, Tube or Other) at angles of 45°, 90° or 135° as needed;
- Helps like a 3rd hand in positioning and holding jobs on ferrous surfaces;

MODEL	MIMPH25	MIMPH3	MIMPH35	MIMPH5
SIZE	2.5"/57mm	3"/75mm	3.62"/92mm	4.56"/116mm
WEIGHT	176 gms	335 gms	778 gms	947 gms
QUANTITY	50 Pcs	50 Pcs	30 Pcs	20 Pcs

Yellow colour also available

WELDING

SOLDERING

ASSEMBLY

MARKING OFF

PIPE INSTALLATION

AS A SEPARATOR

MULTI-UNITS FOR HEAVY WELDMENTS

FOR LIFTING

See Chart Below For Dimensions

MODEL	MIMPH25	MIMPH3	MIMPH35	MIMPH5
DIMENSION A	57 mm	75 mm	92 mm	116 mm
DIMENSION B	62 mm	70 mm	93 mm	125 mm
SUPPORT WL	28 Lb (12.5 Kg)	45 Lb (20 Kg)	80 Lb (36 Kg)	95 Lb (43 Kg)
DIRECT LIFT CAPACITY	4.3 Lb (2 Kg)	9.10 Lb (4.10 Kg)	20.3 Lb (9.20 Kg)	33 Lb (15 Kg)

MINOZGEL3
Net Wt. 300 gms
Plastic Jar

MINOZGEL5
Net Wt. 500 gms
Plastic Jar

Tin can also available
MINOZGELT3
Net Wt. 300 gms
Plastic Jar

Nozzle Dip Anti-Spatter Gel

MIWG8
Cam type weld gauge

Measures fillet leg length and weld throat size. Undercut and pitting depth. Excess weld metal, root and face gap, angle of preparation and misalignment.

100 Pcs

MIWG11
Weld fillet gauge

Measures 11 fillet weld sizes for concave or convex welds.

100 Pcs

Technical Data

Table1 (EN 60974-11) - Relation of the electrode holder rating to the size of electrodes and welding cables

Electrode Holder Rating A	Minimum clamping range for electrodes core diameter mm ²	Minimum fitting range for welding cable cross-sectional area mm ²
125	1,6 to 2,5	10 to 16
150	2 to 3,2	16 to 25
200	2,5 to 4	25 to 35
250	3,2 to 5	35 to 50
300	4 to 6,3	50 to 70
400	5 to 8	70 to 95
500	6,3 to 10	95 to 120

Table2 (EN 60974-12) - Relation between coupling device rating and welding cables

Coupling device rating A	Minimum fitting range for welding cable cross-sectional area mm ²
125	up to 10
150	10 to 16
200	16 to 25
250	25 to 35
300	35 to 50
400	50 to 70
500	70 to 95

Table 3 - Comparison Table AWG - mm²

AWG	mm ²
6/0	170.3
5/0	135.1
4/0	107.2
3/0	85.0
2/0	67.5
0	53.4
1	42.4
2	33.6
3	26.7
4	21.2
5	16.8
6	13.3
7	10.6
8	8.35
9	6.62

Table 4 - Dark Glass Shade No. Table

Welding Process	Arc Current (Amperes)																								
	5	15	30	40	60	70	100	125	150	175	200	225	250	300	350	400	500								
MMAW	5				9			10			11			12			13								
MAG					8			9			10			11			12			13					
TIG	8				9			10			11			12			13								
MIG with heavy metals								9			10			11			12			13					
MIG with light alloys											10			11			12			13					
Air-arc gouging											10			11			12			13			14		
Plasma jet cutting								9			10			11			12			13					
Micro plasma arc welding	4	5	6	7	8	9	10	11	12	13															
	5	15	30	40	60	70	100	125	150	175	200	225	250	300	350	400	500								

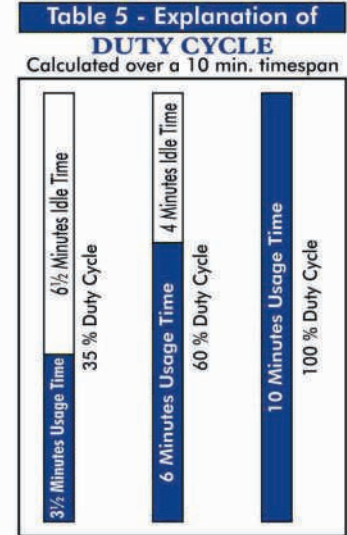

Table1 (EN 60974-11) - Relation of the electrode holder rating to the size of electrodes and welding cables

Electrode Holder Rating A	Minimum clamping range for electrodes core diameter mm ²	Minimum fitting range for welding cable cross-sectional area mm ²
125	1,6 to 2,5	10 to 16
150	2 to 3,2	16 to 25
200	2,5 to 4	25 to 35
250	3,2 to 5	35 to 50
300	4 to 6,3	50 to 70
400	5 to 8	70 to 95
500	6,3 to 10	95 to 120

Table2 (EN 60974-12) - Relation between coupling device rating and welding cables

Coupling device rating A	Minimum fitting range for welding cable cross-sectional area mm ²
125	up to 10
150	10 to 16
200	16 to 25
250	25 to 35
300	35 to 50
400	50 to 70
500	70 to 95

Table 3 - Comparison Table AWG - mm²

AWG	mm ²
6/0	170.3
5/0	135.1
4/0	107.2
3/0	85.0
2/0	67.5
0	53.4
1	42.4
2	33.6
3	26.7
4	21.2
5	16.8
6	13.3
7	10.6
8	8.35
9	6.62

Table 4 - Dark Glass Shade No. Table

Welding Process	Arc Current (Amperes)																								
	5	15	30	40	60	70	100	125	150	175	200	225	250	300	350	400	500								
MMAW	5				9			10			11			12			13								
MAG					8			9			10			11			12			13					
TIG	8				9			10			11			12			13								
MIG with heavy metals								9			10			11			12			13					
MIG with light alloys											10			11			12			13					
Air-arc gouging											10			11			12			13			14		
Plasma jet cutting								9			10			11			12			13					
Micro plasma arc welding	4	5	6	7	8	9	10	11	12	13															
	5	15	30	40	60	70	100	125	150	175	200	225	250	300	350	400	500								

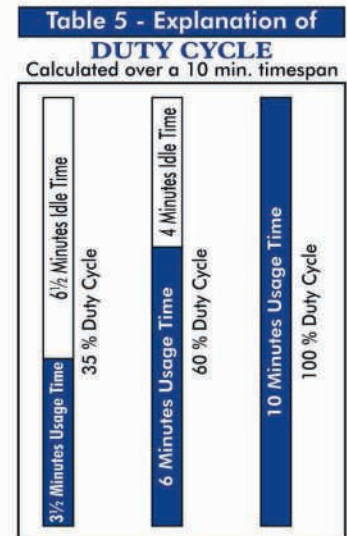

OEM Supplier to the World

2,00,000 Sq. ft Manufacturing Facility

Strong R&D Team

600 Dedicated Workforce

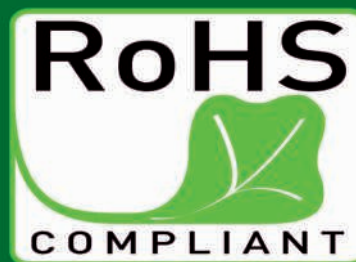

Materials Used

For more details on our range of products kindly visit our website.



Manufactured by:

WELSPRING UNIVERSAL

43 km, Milestone, NH-10, Delhi

Rohtak Road, Bahadurgarh -124507, Haryana, INDIA

Phone: 01276-666 000, 666 066

Regd. Office:

B-19 Mayapuri Phase 1, New Delhi - 110064, INDIA.

Email : welspring@welspring.com

Website : www.welspring.com



Channel Partner - South India

CENTROID ENGINEERS INDIA PRIVATE LIMITED

378, DR NANJAPPA ROAD, COIMBATORE - 641 018.

Phone : 0422 - 438 0072, 438 0073

E-mail : info@centroid.in / sales@centroid.in

Website : www.centroid.in

personal protective equipments





W HEAPRO

**THINK SAFETY
& ACT SAFELY**

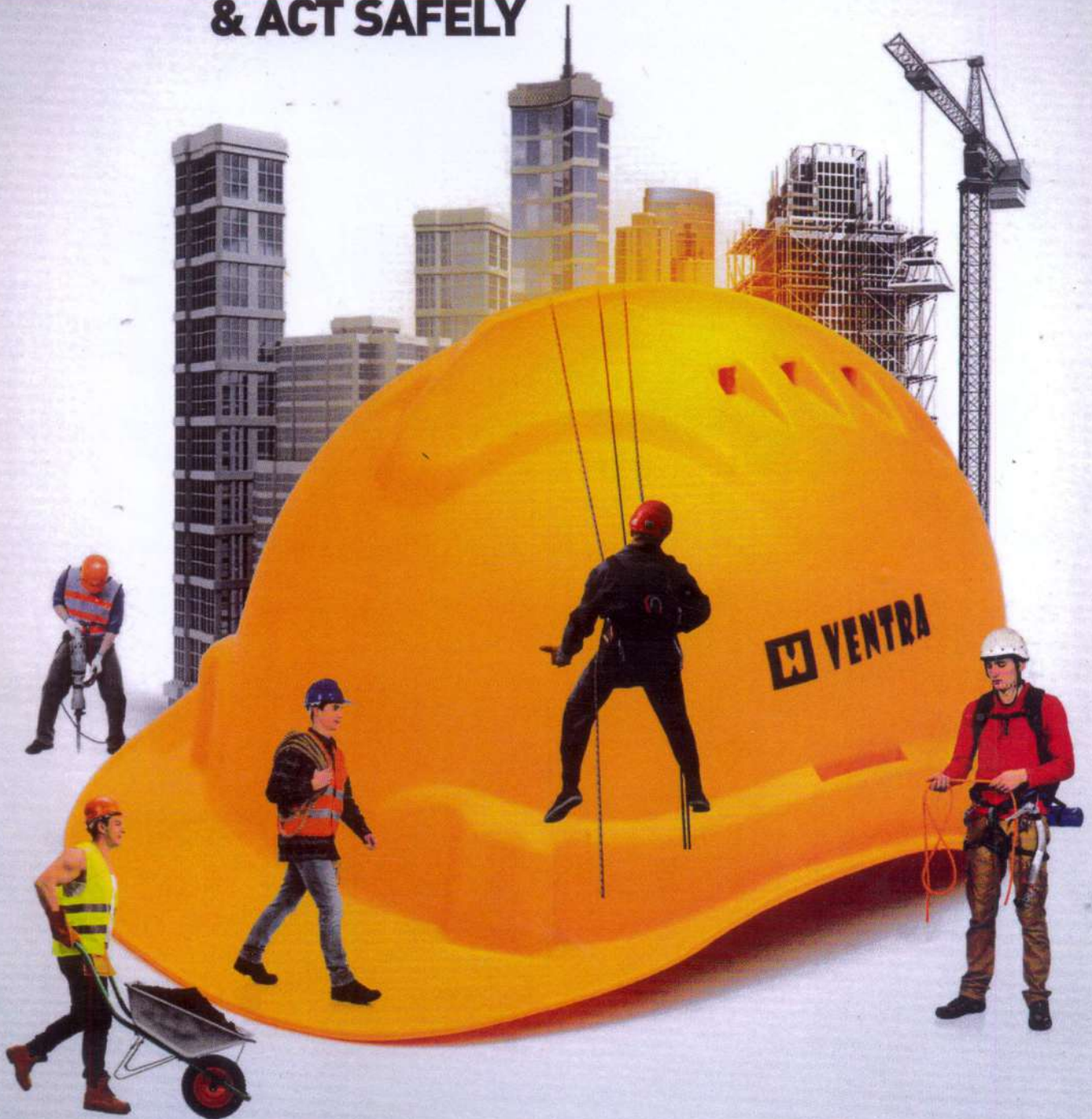

C A T A L O G U E 2 0 1 7

CMC is TS 16949:2009 certified company as it has a base to manufacture sub-assemblies for automobile O.E.M.'s. The safety products are manufactured by following the same system as for automotive and conforming to BIS norms. At HEAPRO all products go through rigorous testing stages to make sure that each equipment is strong and safe.



TESTING FACILITY

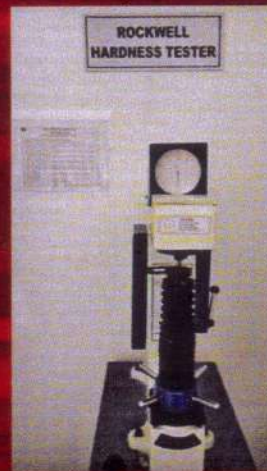

QUALITY POLICY

We believe that quality comes by habit not by cost. Manufacturing the best products in a still better way to improve with each & every count can do wonders.

CERTIFICATION

FOR SYSTEMS - TS 16949:2009
FOR PRODUCTS - AS PER BUREAU OF INDIAN STANDARDS



ISO/TS 16949:2009

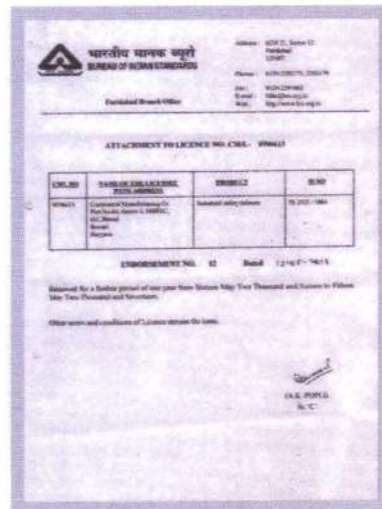

IS 2925 : 1984
SAFETY HELMETS



IS 3521:1999 SAFETY
BELT & HARNESS

ABOUT US

Established in 1990 Continental Manufacturing Co. was set up to produce high precision components for automotive sector. After successfully working in the manufacturing segment it was observed that awareness of safety standards and use of right equipment was not satisfactory. Also high quality PPE's were not easily available.

Thus CMC gave birth to its baby 'HEAPRO' to make each life fear free from accident at workplace especially while working at height. With requisite experience in sheet metal & plastics HEAPRO PPE's were introduced to make each individual so confident that working at height becomes his passion.

HEAPRO is a name of prominence, reliability and trust in the market of personal protective equipments. For over a decade now HEAPRO is a leading brand manufacturing specialized equipments for every personnel working at higher altitudes.

With advanced architecture and buildings getting taller all HEAPRO equipments go through rigorous testing procedures while manufacturing so as to achieve ZERO DEFECT.

Our team of experienced professionals is constantly innovating ideas for making safety equipments ideal and comfortable for use.

At HEAPRO we strive to provide you the best and will, continue to do so.



HEAPRO SAFETY HELMETS



Made from special grade high density PE
 Light weight yet strong to ensure extended working hours
 Available in smart vented & unvented designs
 Louvers for cross ventilation in Heapro Ventra series
 Cushion pad for wearer's comfort
 Available in Pin Lock & Ratchet Design
 Skin Friendly Sweat Pad, Chin Strap & Cushion Pad
 Four point suspension
 Conforms to IS:2925-1984

HEAPRO VENTRA SERIES

Product Code	Model	Description
VL-0011	VENTRA LD	Pin lock type plastic harness with HDPE shell
VRD-0011	VENTRA LDR	Ratchet type plastic harness with HDPE shell
VY-0011	VENTRA LDY	Y strap type plastic harness with HDPE shell
VLD-0022	VENTRA LD 2H	Pin Lock type plastic harness with ABS shell
VR-0022	VENTRA LDR 2H	Ratchet type plastic harness with ABS shell



Colours Available :



You can customize with Your own text and/or Logo. Printing / sticking is Possible on the front and side of the helmet. Ask for our Favorable pricing.



HEAPRO STANDARD SERIES

Product Code	Model	Description
HSD-001	HEAPRO SD	Pin lock type plastic harness with HDPE shell
HR-001	HEAPRO SDR	Ratchet type plastic harness with HDPE shell
HY-001	HEAPRO SDY	Y strap type plastic harness with HDPE shell
HSD-002	HEAPRO SD 2H	Pin Lock type plastic harness with ABS shell
HR-002	HEAPRO SDR 2H	Ratchet type plastic harness with ABS shell

Colours Available :



The risk of head injury at work place is very common and should be taken care of in all circumstances. The use of safety helmets or hard hats prevents a worker from impact of a falling or flying object. Even a very small object falling from a height can cause a serious injury to a worker's head.

HEAPRO safety helmets are so designed as to protect and reduce the impact of any penetration or shock of a blow that may occur while in mining, construction, power and fabrication environments.

Although safety helmets provide limited safety against hazards at work place however if worn correctly, the right head gear ensures that most of the head injuries can be avoided or reduced thus protecting life of a worker.

Accessories like torch light, ear muffs and welding shields can also be used with manufacturer's guidelines.



Ratchet



Sweatband



Adjustable Quick Fit Pin Lock



Harness Comfort Cushion Pad

SAFETY HELMET

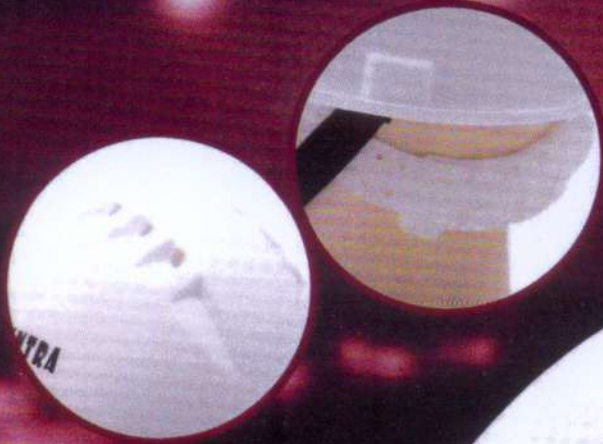

LOUVERS FOR CROSS
VENTILATION



CARE AND USES OF HARNESS

A fall arrest system is required if any risk exists that a worker may fall from an elevated position. As a general rule, the fall arrest system should be used anytime a working height of six feet or more is reached. Working height is the distance from the walking/working surface to a grade or lower level. A fall arrest system will only come into service should a fall occur. A full-body harness with a shock-absorbing lanyard are preferably recommended. A full-body harness distributes the forces throughout the body, and the shock-absorbing lanyard decreases the total fall arresting forces.

Inspection of Harness and Lanyard before use

1. Check that the fall indicator is not damaged. Damaged fall indicator indicates that the harness has been subjected to accident. Thus harness is unfit for use.
2. Webbing should be free from natural wear & tear, cut or loose fibres.
3. There should be no cut in stitching or broken thread coming out at any point.
4. All metal parts should be free from rust, crack, deformation or damage.
5. Inspect the rope for any visual damage, wear & tear. The rope is not fit for use if the colour fibre life indicator has faded.



How to Wear a Harness



Step 1
Hold harness by back D-ring, Shake harness to allow all straps to fall in place



Step 2
If chest, leg and/or waist straps are buckled, release straps and unbuckle at this time.



Step 3
Slip straps over shoulders, so D-ring is located in middle of back between shoulder blades.



Step 4
Pull leg straps between legs and connect to opposite end. Repeat with second leg strap. If belted harness, connect waist strap after leg straps



Step 5
Connect chest strap and position in mid chest area. Tighten to keep shoulder straps taut



Step 6
After all straps have been buckled, tighten all buckles so that harness fits snug but allows full range of movement, Pass excess strap through loop keepers

SAFETY HARNESS

A fall from height can be fatal without the use of right protective gear and training on how to use it. With buildings getting taller and using advanced architecture, the risk of falling has also increased manifold.

HEAPRO harnesses are manufactured on automatic machines using dope dyed high strength German yarn for reliable stitching

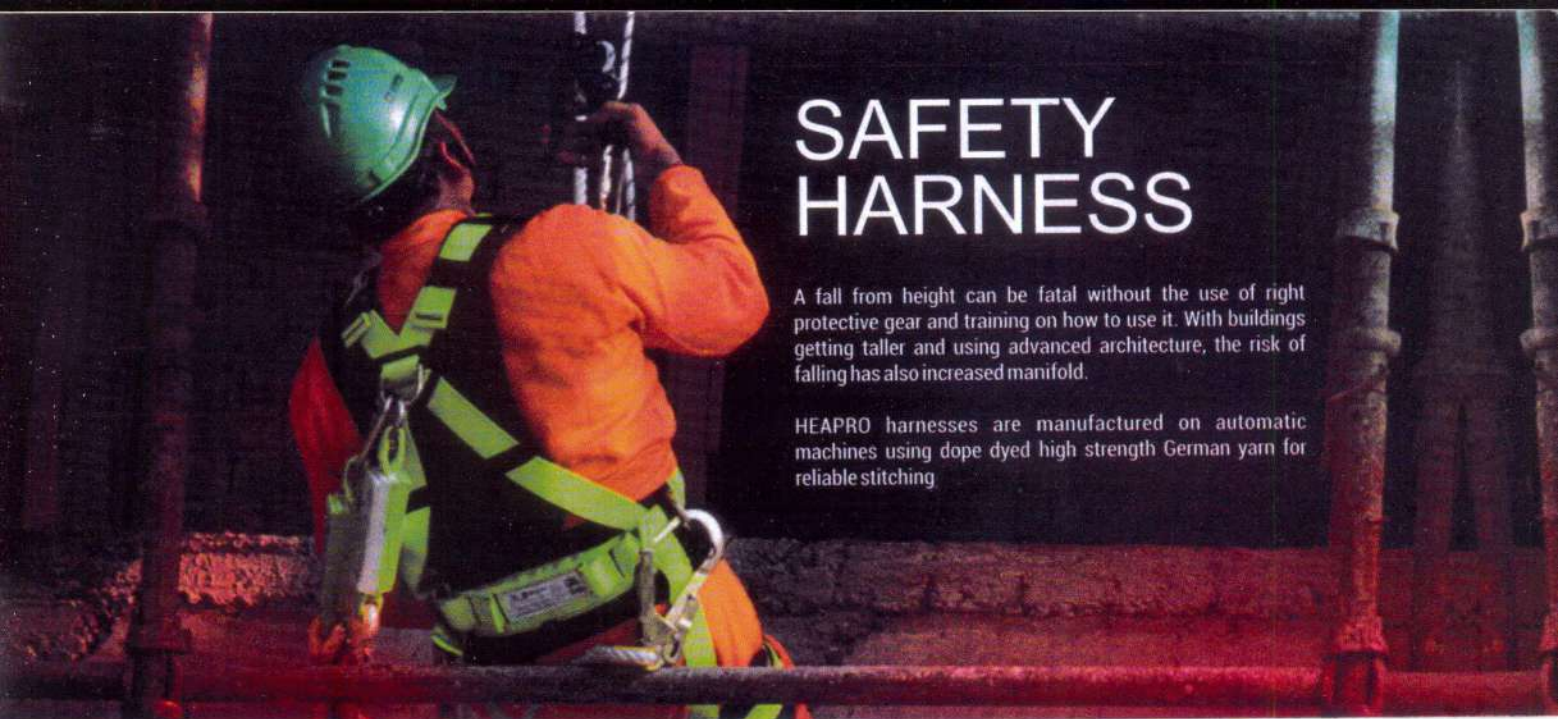

CLASS-A (For basic Fall Arrest)

Product Code : HI-32

- ISI Mark : Conforms to ISI 3521:1999
- Special Grade forged steel used for high tensile strength
- Polyester webbing with high breaking strength
- Zinc plated metal parts

Attachment Elements: A Dorsal attachment D-Ring for Fall Arrest

Adaptability: Adjustable Chest-Strap & Thigh-Straps



CLASS-D (For Controlled Descent)

Product Code : HI-28

- ISI Mark : Conforms to ISI 3521:1999
- Special Grade forged steel used for high tensile strength
- Polyester webbing with high breaking strength
- Zinc plated metal parts

Attachment Elements: Sternal D-Ring at the front is use in the event of controlled decent from height. A Dorsal Attachment D-Ring for Fall Arrest.

Adaptability: Adjustable Thigh-Straps.



CLASS -E (For Entry & Exit in Confined)

Product Code : HI-38

- ISI Mark : Conforms to ISI 3521:1999
- Special Grade forged steel used for high tensile strength
- Polyester webbing with high breaking strength
- Zinc plated metal parts

Attachment Elements: Two Sliding D-Rings one on each shoulder strap, this helps into confined spaces. A dorsal attachment D-Ring for Fall Arrest.

Adaptability: Adjustable Chest-Strap & Thigh-Straps.



CLASS -P (For Work Positioning)

Product Code : HI-34

- ISI Mark : Conforms to ISI 3521:1999
- Special Grade forged steel used for high tensile strength
- Polyester webbing with high breaking strength
- Zinc plated metal parts

Attachment Elements: A Dorsal Attachment D-Ring helps in positioning the worker so that he can work with both hands free.

Adaptability: Adjustable Chest-Strap & Thigh-Straps.



CLASS -L (For Ladder & Tower Climbing)

Product Code : HI-56

- ISI Mark : Conforms to ISI 3521:1999
- Special Grade forged steel used for high tensile strength
- Polyester webbing with high breaking strength
- Zinc plated metal parts

Attachment Elements: 2 chest attachment D-Ring for tower climbing. A Dorsal Attachment D-Ring for Fall Arrest.

Adaptability: Adjustable Chest-Strap, Shoulder Strap & Thigh-Straps.

LOOP COMBINATIONS

Description	Image	Code	Image	Code	Image	Code	Image	Code
Twisted Rope Lanyard		HI 402		HI 404		HI 408		HI 412
Kernmantle Rope Lanyard		HI 562		HI 564		HI 568		HI 572
Webbing Lanyard		HI 442		HI 444		HI 448		HI 452
Energy Absorbing Twisted Rope Lanyards		HI 602		HI 604		HI 608		HI 612

KARABINER COMBINATIONS

Description	Image	Code	Image	Code	Image	Code
Twisted Rope Lanyard		HI 406		HI 414		HI 416
Kernmantle Rope Lanyard		HI 566		HI 574		HI 576
Webbing Lanyard		HI 446		HI 454		HI 456
Energy Absorbing Twisted Rope Lanyards		HI 606		HI 614		HI 616

SNAP HOOK COMBINATIONS

Description	Image	Code	Image	Code
Twisted Rope Lanyard		HI 410		HI 418
Kernmantle Rope Lanyard		HI 570		HI 458
Webbing Lanyard		HI 450		HI 578
Energy Absorbing Twisted Rope Lanyards		HI 610		HI 618

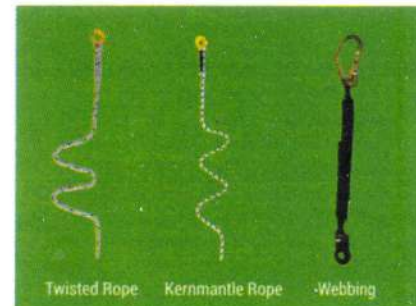

Work Positioning Lanyard with Ring Type Adjuster
Product code: HI 482

- Made up of 14 mm dia polyamide 3-strand twisted rope.
- Max. Length 2.0 meter.
- Manual Ring Type adjuster of forged alloy steel.
- Easy to connect Steel Karabiner at both the ends for attachment.
- Also available with a 300 mm long protective covering sleeve.

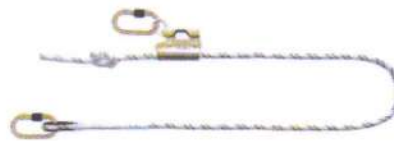

Work Positioning Lanyard with Grip Adjuster
Product code: HI 490

- Made up of Kernmantle rope of dia 10.5 mm
- Max. Length 2.0 meter.
- Rope grab adjuster for easy length adjustment.
- Easy to connect Steel Karabiners at both the ends for attachment.
- Also available with a 300 mm long protective covering sleeve.



Work Positioning Lanyard with Ring Adjuster
Product code: HI 488

- Made up of Kernmantle rope of dia 10.5 mm
- Max. Length 2.0 meter.
- rope grab adjuster for easy length adjustment.
- Easy to connect Steel Karabiner at both the ends for attachment.
- Also available with a 300 mm long protective covering sleeve.



Work Positioning Lanyard with Grip Adjuster | Product code: HI 484

- Made up of 14 mm dia polyamide 3-strand twisted rope.
- Max. Length 2.0 meter.
- Equiped with convenient rope grab adjuster for easy length adjustment.
- Easy to connect Steel Karabiner at both the ends for attachment.
- Also available with a 300 mm long protective covering sleeve.



Webbing Work Positioning Lanyard with Ring Adjuster | Product code: HI 486

- Made up of 33 mm wide polyester webbing.
- Max. Length 2.0 meter.
- Manual Ring type adjuster of forged alloy steel.
- Easy to connect Steel Karabiner at both the ends for attachment.
- Also available with a 300 mm long protective covering sleeve.



FORKED LANYARDS



Product Code	Image	Description	Length
HI 682-KE		Energy Absorbing forked Kernmantle Rope Lanyard with Karabiner Hook Connector at Harness end and 2 nos of Scaffold Hooks at Anchorage end.	2 Meter
HI 682-SE		Energy Absorbing forked Kernmantle Rope Lanyard with Snap Hook Connector at Harness end and 2 nos of Scaffold Hooks at Anchorage end.	2 Meter
HI 682-KS		Energy Absorbing forked Kernmantle Rope Lanyard with Snap Hook Connector at Harness end and 2 nos of Snap Hooks at Anchorage end.	2 Meter
HI 702-KR-SE-D		Kernmantle Rope forked lanyard with Snap hook Connector at Harness end and 2 Nos of Scaffold hooks at Anchorage end.	2 Meter

Product Code	Image	Description	Length
HI 702-KE		Energy Absorbing forked Polyamide Rope Lanyard with Karabiner Hook Connector at Harness end and 2 nos of Scaffold Hooks at Anchorage end.	2 Meter
HI 702-SE		Energy Absorbing forked Polyamide Rope Lanyard with Snap Hook Connector at Harness end and 2 nos of Scaffold Hooks at Anchorage end.	2 Meter
HI 704		Energy Absorbing forked Polyamide Rope Lanyard with Snap Hook Connector at Harness end and 2 nos of Snap Hooks at Anchorage end.	2 Meter

Product Code	Sketch	Description	Length
HI 722		Energy Absorbing forked Polyester Webbing Lanyard with Karabiner Hook Connector at Harness end and 2 nos of Scaffold Hooks at Anchorage end.	2 Meter
HI 722-SE		Energy Absorbing forked Polyamide Rope Lanyard with Snap Hook Connector at Harness end and 2 nos of Scaffold Hooks at Anchorage end.	2 Meter





MULTIPURPOSE HARNESS

Product Code HI-112



HEAPRO manufactures high quality safety harnesses for use in different applications. HEAPRO multipurpose harness is suitable in most situations like tower climbing, facade painting and window maintenance, rescue operations etc.

Multipurpose harness has following salient feature:

- Fully adjustable with rope access
- Comfort pad at shoulder waist and thighs enhances efficiency of a worker during long working hours.
- Suitable for work positioning, fall arrest and work restraint situations.

FALL ARRESTERS



HEAPRO Fall Arrester move easily up and down vertical lifelines to provide continuous fall protection. Trailing models offer complete hands-free operation for increased productivity. In the event of a fall, HEAPRO Fall Arrester locks quickly.

- Compact design; corrosion-resistant stainless steel construction
- Lightweight and easy to use



OPENABLE TYPE FALL ARRESTER
Heapro Openable type Fall Arrester made up of High Strength steel & works on 14 to 16 mm dia Polyamide Rope

Conforms to EN-353-2
Product Code : HFA01



NON-OPENABLE TYPE FALL ARRESTER
Non Openable type fall arrester works on 12mm kernmantle rope. It is generally used on platforms & roofs to prevent a worker from falling in the event of slipping.

Conforms to EN-353-2
Product Code : HRG 01

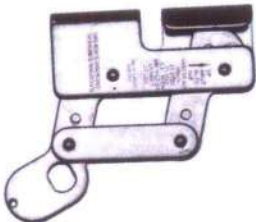

WIRE ROPE GRAB
Heapro Wire Rope Grab made up of High Strength Stainless steel & works on 8 mm dia of Steel Wire.

Conforms to EN-353-1
Product Code : HRG02



HEAPRO ENERGY ABSORBER
Heapro Energy absorber is made up of 44 mm wide webbing & shrink wrapped. It reduces the impact of fall to less than 6kN.

The minimum fall clearance distance required for using Heapro energy absorber for 2 meter lanyard is 6 m.

Conforms to EN-355
Product code: HEA01

CONNECTORS

HEAPRO Connectors are made up of high tensile steel , Tested for corrosion resistance for Min. 72 Hrs of Salt Spray test.



SCAFFOLDING HOOK
Product Code : HI-262E
Conforms to EN-362
Material: Forged Alloy Steel
Opening : 55 mm | Strength : > 20 kN



SNAP HOOK
Product Code : HI-242
Conforms to EN-362
Material: Alloy Steel
Opening : 18 mm | Strength : > 20 kN



KARABINER HOOK
Product Code : HI-224K
Conforms to EN-362
Material : Alloy Steel
Opening : 15 mm | Strength : > 20 kN



SPRING HOOK
Product Code : HI-224S
Conforms to EN-362
Material : Alloy Steel
Opening : 15mm | Strength : >20 kN



HEAPRO MAINTENANCE & WINDOW CLEANING KIT



Multipurpose Harness
HI-112 (01 Nos)



Anchorage Rope HI 1900
(14mm) (50 mtr.)



Kernmantle Rope
HI-1900K (50 mtr.)



Karabiner
HI-224 (03 Nos)



Descender
DS 01 (01 Nos)



Tool Bag
HTB 01 (01 Nos)



Fall Arrester
HFA01 (01 Nos)



Webbing Sling
HI-1606 (02 Nos)



Heapro Swing Seat
HSS01 (01 Nos)



HeaproMan's Kit Bag
HKB 01

TOWER KIT

HEAPRO



Multipurpose Harness
HI-112 (01 Nos)



Fall Arrester
HFA01 (01 Nos)



Tool Bag
HTB 01 (01 Nos)



Work Positioning
Lanyard HI-484 (01 Nos)



Anchorage Rope HI 1900
(14mm) (50 mtr.)



Forked Lanyard
HI-702 PA-SE-D



HeaproMan's Kit Bag
HKB 01





HEAPRO RESCUE KIT

PRODUCT CODE : HRK01



Multipurpose Harness
HI-112 (01 Nos)



Work Positioning Lanyard
HI-484 (01 Nos)



Webbing Sling
HI-1606 (02 Nos)



Cows Tail
HI-802 (01 Nos)



Fall Arrester
HFA01 (01 Nos)



Karabiner
HI-224 (03 Nos)



Anchorage Rope HI 1900
(14mm) (50 mtr.)



Descender
DS 01 (01 Nos)



Forked Lanyard
HI-682 KE (01 Nos)



Kernmantle Rope
HI-1900K (50 mtr.)



HeaproMan's Kit Bag
HKB 01



FEATURES

UPPER LEATHER	BUFF SPLIT BARTON 1.8-2.0MM
EYELET 'U' PART	SPLIT BARTON THICK NESS 1.1-1.3MM
TONGUE	PU COAGULATED
LINING	DISTANCE MESH GREY
VAMP LINING	NONWOVEN
INSOLE	200 J
METAL FITTING	EYE LET
SOCKS	FABTEX WITH EVA CUSHIONING
SOLE	SINGLE DENSITY-22

ANKLE (MODEL-SB PU402)



DERBY (MODEL-SB PU401)



REFLECTIVE WORK WEAR

Get your Reflective work wear customized from HEAPRO



www.centroid.in



garage equipment & tools





pentaTM



**Automobile Service Equipment
& Tools**

Catalogue 2017



India | Sri Lanka | Bangladesh | UAE | Kuwait | Kenya



Production Team



Manufacturing Facility











Technical, Administrative
& Marketing Team

Hand Operated Grease Dispenser	1
Pneumatic Grease Dispenser	2
Pneumatic Barrel Grease Pump	3
Pneumatic Barrel Oil Pump	3
Waste Oil Collector	4
Hand Operated Oil Dispenser	5
Hand Greaser (Lever Type)	5
High Pressure Washer	6
Air Compressor	7
Hydraulic Washing Lift	8
Hydraulic Floor Crane	8
Hydraulic Trolley Jack	9
Hydraulic Bottle Jack	10
Hydraulic Two Wheeler Lift	11
Mechanic Creeper	12
Axle Stand	13
Rotary Barrel Pump	13
Tyre Inflator	14
Compression Tester - Petrol	14
Bearing Puller	14
Automobile Special Tools	15

Hand Operated Grease Dispenser



							
3						265x265x510	6.2
5	5500	4	2 Metres	Thermoplastic/ Rubber Hydraulically crimped	Provided	275x260x580	8.5
10						305x300x580	9.3
20						355x355x710	13.7

Accessories



Grease Hand Gun



Delivery Hose with Hand Gun



Kg		Ratio	PSI	Gms/min	Hose			LBH mm	Kgs
5								275x290x740	11.7
15	Pneumatic	50 : 1	8500	700	2 Metres	Thermoplastic/ Rubber	Provided	330x280x865	20.0
25						Hydraulically crimped		460x360x1000	25.2
50								560x485x1060	41.0



Pneumatic Hand Gun



Pneumatic Barrel Grease Pump



205	Pneumatic	50 : 1	8000	350	2 Metres	Thermoplastic/ Rubber Hydraulically crimped	Provided

Pneumatic Barrel Oil Pump



200	Pneumatic	10	2 Metres	Rubber/PVC Hydraulically crimped





Ltr	Bar	Min. H:mm	Max. H:mm	Kgs	LBH mm
50 M	-	920	1100	20.8	550x465x920
50 P	4-6	1285	1530	22.25	565x495x1285
50 T	4-6	335	-	50.0	1625x765x335

Pressure Evacuation System



Waste Oil Collector for Heavy Vehicle

Hand Operated Oil Dispenser

Ltr	ml/St	Hose		LBH mm	Kgs
5	75	2 Metres	Rubber/PVC Hydraulically crimped	220x260x560	9.45
20				335x335x705	12.8



Delivery Hose with Hand Gun



Hand Greaser (Lever Type)



CC	Gms	PSI	Gms/St	LBH mm	Kgs
175	198	2500	2	265x120x85	0.9
350	400	3000	2.5	390x145x85	1.45
500	575	3000	2.5	390x145x85	1.7
750	860	3000	2.5	475x175x85	2.1



Three Piston Pump



Single Piston Pump



Aluminium Hand Gun



Brass Hand Gun

PE 50	15	8	1.0		500	230			700x370x460	60
PE 100	18	8	1.5	1440	360	230	50	5	750x410x550	70
PE 200	25	13	2.0		360	230/415			750x410x550	70
PE 300	40	15	3.0		360	230/415			775x410x550	75

Weight Mentioned without Motor

Air Compressor



Triple Cylinder







Twin Cylinder



Single Cylinder



Aluminium Co-axial

				
PAS200AM	2.0 HP	25 Lts	3.1	6
PAS 100	1.0 HP	90 Lts	2.9	8
PAS 200	2.0 HP	160 Lts	6.8	9
PAS 200T	2.0 HP	160 Lts	6.9	9
PAS 300T	3.0 HP	220 Lts	10.9	9
PAD 500T	5.0 HP	250 Lts	17.7	12
PAD 1000T	10.0 HP	500 Lts	35.4	12
PAD 1500T	15.0 HP	500 Lts	54.3	12

Hydraulic Washing Lift



4	1	265 mm	10 Kg/Cm ²	1500 mm	175x85x4500 mm	160 Ltrs

Hydraulic Floor Crane



Crane in folded position



2	600	2370	130	280	1555x930x1580	103

Hydraulic Trolley Jack



5.0 Ton









3.0 Ton Double Plunger



10.0 Ton

Ton	LB mm	mm	mm	mm	mm	Kgs
3	675x125	500	135	373	-	38
5	1400x410	540	190	350	1165	142
10	1650x480	540	200	340	1165	180











						
PJ 0204	2	158	260	90	50	2.2
PJ 0304	3	168	328	100	60	2.8
PJ 0504	5	195	325	125	60	3.3
PJ 0804	8	200	330	125	60	5
PJ 1504	15	225	385	140	60	7.7
PJ 2004	20	235	395	145	60	10
PJ 3004	30	255	430	150	NA	13
PJ 5004	50	285	485	180	NA	21
PJ 10004	100	265	520	255	NA	68



Hydraulic Two Wheeler Lift



Manual - A

							
A	-	-	1870x550	210	750	200	133
B	230	50	1870x550	200	750	200	145



Motorised - B

0.5 hp High Torque motor coupled with powerful hydraulic pump



Foot operated hydraulic system





Regular

920x430x85	920x430x110	6.3	90



Foldable

460x460x360	920x460x125	7.4	90



Release Pin



Axle Stand



Ton	mm	mm	mm	Kgs
2	270	360	90	3.0
3	270	390	120	3.3
6	330	510	180	8.8
12	330	480	150	10.5
22	310	490	180	16

Rotary Barrel Pump



200 ml	1400mm
--------	--------



For Two / Four Wheelers



For Heavy Vehicles

Compression Tester - Petrol



Bearing Puller



Model 1935

19mm to 35mm



Model 3580

35mm to 80mm



Design & Development



Welding & Fabrication



CNC Machining



Machining



Liquid Painting



Powder Coating



Wrapping & Packing



Centralised Store

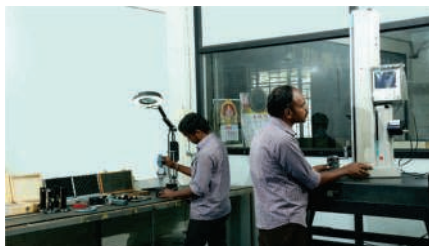

Quality Assurance



Conference



Administration

penta[™]

Penta Auto Equipments Pvt Ltd

Coimbatore - 641 105, Tamilnadu, India

T : 0422 - 262 2660 / 80, E : info@pentaIndia.com, W : pentaIndia.com

Due to continuous development, Dimensions, Specifications and Models are subject to change without prior notice.
The Photographs and pictures printed in the catalogue are not to be copied or used without legal consent.

general hand tools



PRECISION MEASURING & TESTING INSTRUMENTS



Mitutoyo

Mahr

Starrett



KEN CY



STANLEY



TECLOCK



ElektroPhysik



UNI-T BAKER

KRISTEEL



KROPLIN



Snap-on



FLUKE



FIEBIG

Koba

Micrometers, Vernier Calipers, Dial Gauges, Thickness Gauges, Depth Gauges, Height Gauges, Block Levels, Slip Gauges, Surface Plates, Groove Gauges, Thread Gauges, Plug Gauges, Measuring Scales, Measuring Tapes, Precision Squares, Angle Plates, Protractors, Magnetic V Blocks, Feeler Gauges, Tachometers, Coating Thickness Testers, Pistol Calipers, Metal Detectors, Hardness Testers, Anemometers, Stroboscopes, Multimeters, Tongtesters, PH Meters, Conductivity Meters, O₂ Meters, Sound level Meters, Lux Meters, Hygro Meters, Rubber Hardness Testers, Bearing Testers, Revolution Counters, Road-O-Meters, Bore Gauges, Pressure Gauges, Precision Weighing Machines, Tension Meters, Industrial Magnifiers, Refractometers, Surface Roughness Comparators, Roughness Testers, Gloss Meters, Oscilloscopes, Paint Thickness Testers, Weld Gauges, Pin Gauges, Moisture Meters, Crack Detectors, Pin Hole Detectors, Magnifiers, Microscopes, Weights, Textile Measuring Equipments and Electrical Instruments.



STANLEY

PENTAX



SOKKIA

SKIL

TOPCON

Leica

Total Station, Theodolite, Laser Leveler, Rotary Laser Leveler, Electronic Distance Meter Auto Leveler, Cross Staff, Plumb Bob, Spirit Level, Digital Spirit level

LEVELING INSTRUMENTS

GENERAL HAND TOOLS



CROS

BAHCO

BLACK HAWK

Wiha

TAPARIA

Snap-on

STANLEY

Williams

FACOM

BULLWARK

MULTITEC

HAZET

BONDHUS

Kabage

Blue-Point

STAHLWILLE

BLACK & DECKER

KING TONY

penta

Eastman

Talbro

DRED

GEDORE

ORBIT

ELORA

GB

Prima

IRWIN Industrial Tools

KNIPEX

Wera

BOSTITCH

Weidmüller

TOPTUL

felo

COOPER

AmPro

BESSEY

ROCK ROX REX

MAGADH

ORBS

SOLDRON

RIDGID

Spanners, Wrenches, Cutting Pliers, Screw Drivers, Torque Wrenches, Sockets, Socket Accessories, Hammers, Bearing Pullers, Tin Cutters, Chisels, Carpentry Jack Planes, Hand Saws, Soldering Irons, Soldering Pastes, Hand Blowers, Carpentry Chisels, Tongs, Clamps, Anvils, Blow Lamps, Vices-Carpentry & Engineering, Swage Blocks, Leg Vices, Oil and Grease Guns, Hydrometers, Box Strapping Tools, Riveting Guns, Lawn Movers, Garden Tools and Blacksmith Tools.



precipreci

CANCO FASTENERS

Walgo

BeckSeal

Starrett

Araldite

LOCTITE

Anabond

ORNIT BLIND RIVETS

Devcon

GE

WERDA

3M

Henkel

SSF

ITW

GENERAL CONSUMABLES & CHEMICALS

Anchor Fastners, Jumper Holders & Bit Sets, Sealants and Adhesives.

CUTTING TOOLS



SOLID CARBIDE DRILLS : End Mills, Reamers, Rocket Mills, Champhering Cutters, Woodruff Cutters and Rotary Burr Inserts.

HSS : End Mills, Drills, Reamers, Slitting Saws, Milling Cutters, Taps and Dies, Tool Bits, Hack Saws, Chasers, Deburring Tools, Band Saws, Adjustable Reamers and Boring Tools.

CARBIDE TIPPED :Drills, Reamers & End Mills, Lathe Tools, Circular Saws.

Hand Files, Bolt Cutters, Grinding Wheels, Diamond Dressers, Diamond Grinding Wheels, Flap Wheels and Mounted Points.

Also available ex-stock Roughing End Mills, Corner Rounding End Mills, Long and Extra Long Drills, Reamers, End Mills, Step Drills and Non Standard Taps.

We can make Custom made Step Drills, Taps, Tipped Tools and Special Cutters in CARBIDES AND HSS.



Paint Spray Guns, Air & Foundry Guns, Artist Spray Guns, Grinding Wheels, Sander Discs, Flap Wheels, Hand Files, Cloth Buffing Wheels, Diamond Polishing Pastes, Diamond Powders, Woollen Polishing Mops, Mounted Points, Fine Grit Emery Papers, Water and Drill Emeries and Automotive Emeries.

FINISH IMPARTING EQUIPMENTS & CONSUMABLES

GARAGE EQUIPMENTS



penta

CROS

ORBIT

BLACK HAWK

BAHCO

STANLEY

Blue-Point

RC RODCRAFT

Snap-on

Chicago Pneumatic

Vein

HOFMANN

GROZ

TVS PROQUAL

FACOM

Wiha

SPIN

ELGI

Kabage

HESHBON

PILOT

PPAMA

ROBINAIR

HANATECH

SEALEY

metabo
work don,t play

ABC
AIR COMPRESSORS

GB

Automobile Special Tools, Hydraulic Trolley Jacks, Hand and Pneumatic Operated Grease Dispensers, Axle Stands, High Pressure Washers, Air Compressors, Two Post Lifts, Hydraulic Service Lifts, Tyre Inflators, Spark Plug Cleaners and Testers, Tool Boxes, Tool Trolleys, Torque Wrenches, Service Creepers, Platform Trolley, Work Benches, Timing Lights, Tech Dwell Testers, Battery Chargers, Battery Testers, Hydraulic Two Wheeler Ramps, Hydraulic Presses, Engine Tachometers, Hand Grease Guns, Oil Cans, Spray Guns, Vernier Calipers, Micrometers, Bore Gauges, Body Straightening Equipments, Vices, Hand Files, Spanners, Screw Drivers, Tow Ropes, Wind Shield Installers, Body Polishing Machines and Consumables.



GOLD FINGER
Safety First

WM

PILOT

ELECTRO WELD

WELDON
WELDING TRANSFORMER

LASER

Asha

ZODIAC

ESAB

MESSER

SAFEX

OERLIKON

INDARC

Arc Welding Machines, Spot & Projection Welding Machines, MIG Welding Machines, TIG Welding Machines, Plasma Cutting Machines, Butt Welding Machines, Gas Torches, LPG Welding Torches, Welding Cables, Welding Electrodes, Tungsten Rods, CO₂ Coils, Filler Rods, PVC Braided Hoses, Cutting Torches, Gas Regulators, Safety Goggles, Welding Holders, Earth Clamps, Electrode Ovens, Safety Gloves, Safety Shoes, Helmets, Hand Shields, Safety Suits, Nose Masks, Face Masks, Industrial Showers, Eye & Face Washers Soldering Wires, Lead Soldering Sticks and Silver Soldering Wires.

WELDING & SAFETY EQUIPMENTS & ACCESSORIES

MACHINE SHOP TOOLS & ACCESSORIES



Revolving and Dead Centres, Drill Sleeves, Quick Change Chucks, Long and Stub Milling Arbors, Collets, Collet Chucks, Tool Post Grinders, Tool Holders, Quick Change Tool Posts, Key and Keyless Drill Chucks, Comparator Stands, Dial Stands, Tapping attachments, CNC Tool Holder and Accessories, Milling Vices, Bench Vices, Tap and Die Wrenches, Micro Boring Heads, Try Squares, Spring Calipers, Punches, Spring Plungers, Machine Tool Accessories, Magnetic Chucks and V Blocks, Angle Plates, Bench Centres, Straight Edges, Surface Plates, Indexing Tables, Diamond Dressers, Tool Boxes, Tool Trolleys, Work Benches, Air Valves, Airline Filter, Regulator and Lubricator, Precision Parallels, Magnets made to size, Straight Edges, Sine Vices, Marking Machines, Burnishing Tools, Micro Boring Heads, Coolant Pipes, Machine Lamps, Toggle Clamps, Clamps, Deburring Tools, PVC and Rubber Braided Hoses, Steel Braided Hydraulic Hoses.

MATERIAL HANDLING EQUIPMENTS



Jib Cranes, Trolley Jacks, Hand Trucks, Pallet Trucks, Stackers, Chain Blocks, Ratchet Hoists, Pulling and Lifting Machines, Mobile Cranes, Hydraulic Jacks, Screw Jacks and Axle Stands.



MARKING SYSTEMS

Electric Marking Machines, Hand Punches - Letters & Numbers, Numbering Machines, Vibratory Markers, Chemical Marking Machines and Label Printers.

MACHINES



Lathes, Drilling Machines, Bench Grinders, Tapping Machines, Cut off Machines, Hand Lever Shears, MIG Welders, TIG Welders, Plasma Cutters, Projection and Spot Welders, Arc Welders, Stud Welders, Hydraulic Pipe Benders, JIB Cranes, Butt Welders, Air Compressors, Vacuum Pumps, Electric Motors, PCB Drilling Machines, Power Hacksaws, Pipe Threaders, Hydraulic Pressure Test Pumps, Fly Presses, Coolant Pumps, Arbor Presses, Coil Winding Machines, Portable Log Cutters, Flexible Grinders, Bench Grinders, Belt Sanders, Wood Working Machines and Pneumatic Power Tools.



TORQUE TOOLS

Torque Wrenches - Click, Dial & Digital, Torque Screwdrivers, Torque Multipliers, Hydraulic Torque Wrenches, Pneumatic Torque Wrenches, Torque Actuated Tools, Oil Pulse Tools, Wonder Wrench.

PNEUMATIC POWER TOOLS & ACCESSORIES



Drilling Machines, Angle Grinders, Marble Cutters, Chop Saws, Routers, Wall Groovers, Planners, Circular Saws, Concrete Breakers, Diamond Cutting Blades, Polishing Wheel and Stones, Concrete Drills, Diamond Core Drills, Tile Cutters, Bonding and Polishing Chemicals.

OFFICE EQUIPMENTS



Paper Shredders, Self Inking Stamps and Vacuum Cleaners.



Drilling Machines, Grinding Machines, Marble Cutters, Torque Wrenches, Vernier Calipers, Micro Meters, Grease Dispensers, High Pressure washers, Welding Machines, Multimeters, Clamp Meters and Timing Lights, etc...

SERVICING UNDERTAKEN FOR

OUR MANUFACTURING ACTIVITY

penta
Automobile Special Tools



Mr. Kumar Venkatachalam
Mob : 93605 00045

Kabage
Tool Boxes & Trolleys



Mr. Chandrakumar
Mob : 93631 04993

BLACK HAWK
Machine Tool Accessories



Mr. Rafiq
Mob : 93666 65151

BULLWARK
Hand Tools



Mr. Sriram
Mob : 93666 66161

OUR ASSOCIATES IN TRADING & SERVICE

ORIENT MACHINERY

For your requirement of industrial machinery.

Mr. Murugesan 98650 93251

CRAFTSMAN CORPORATION

For your requirement of Hand Held power tools.

Mr. Zoeb 94437 54354

MAAP INSTRUMENTATION

For your requirement of measuring instruments.

Mr. Ali Oliia 94425 22350

OPUS SOLUTIONS

For your requirement of packing Machines & Consumables.

Mr. Suresh 94435 84464

ORIENT TRADE & AGENCIES

exclusive dealers operations.

Mr. Yusuf 93444 93800

Mr. Jeyaseelan 94896 68935

CENTROID ENGINEERS INDIA (P) LTD.,

For your requirement of welding equipments & safety products.

Mr. Venkatnarayanan 93603 62200

ORIENT EQUIPMENT & SERVICES

For your calibration and service requirement for any engineering products.

Mr. Raju 98422 65222



KIMEVIC

NOKIA



FEW OF OUR DELIGHTED CUSTOMERS

All trade marks, trade names and / or logos are acknowledged and appearing in this catalogue are property of their respective owners.



Unleash the **POWER** potential . . .

X-POWER
series

SOFT BLOW HAMMERS (Nylon Tipped)

X-POWER
series
(Non rebound)



TIP Ø	MODEL
33.5 mm	XP - 30
43.0 mm	XP - 40
48.5 mm	XP - 50



TIP Ø	MODEL
43.0 mm	XP - 40 NR
48.5 mm	XP - 50 NR

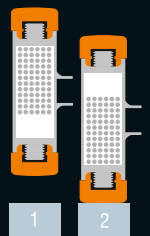

max
force

Soft Blow Mallets



MODEL
MF - 30
MF - 40
MF - 50

Accessories



Soft, Medium, Hard & Metal Tips

Application :

Automobile, Assembly, Body-shop, Engineering Industry, Bearing Assembly, Civil & Masonry, Pump & Motor Industry, Pressure Die Casting, Injection Moulding, Petro Chemical Industry, Aviation, Wind mills, Maintenance, etc.

Tool that empowers.



The raw **POWER** with the strongest **TEETH**

Combination Plier - **CRV**



CP - 8 - 8 Inches
CP - 7 - 7 Inches
CP - 6 - 6 Inches

Stringent Quality Standards

Highest Quality

Assured 5000 Cuttings

Long Nose Plier - **CRV**



LNP - 6 - 6 Inches

Diagonal Cutting Plier - **CRV**



DCP - 6 - 6 Inches

Linemen's Plier - **CRV**



LP - 8 - 8 Inches

- CRV (Chrome Vanadium Steel) Construction.
- Drop forged
- Individually hardened and tempered
- Cutting edges are induction hardened
- Slip resistant design
- Ergonomic rubberised Soft Grip
- Super fine polished finish

Individual Display Packing



Keep the joints of the tool clean & occasionally lubricate with low viscose oil free from acid / resin and enjoy BULLWARK quality for long time.











Bullwark tools are manufactured to international standards and are guaranteed for workmanship & quality.











Always wear goggles and hand gloves.

Bullwark Products January - 2018







S.No	Product	Picture	Description	Model
1	Adjustable Wrenches		6" Length, 19 mm Opening	AW-06
			8" Length, 26 mm Opening	AW-08
			10" Length, 30 mm Opening	AW-10
			12" Length, 35 mm Opening	AW-12
			15" Length, 43 mm Opening	AW-15
			18" Length, 55 mm Opening	AW-18
2	T - Allen Key - Ergo Model		2.5 mm, 145 x 85 mm, Unbreakable Handle	AKT25
			3 mm, 145 x 85 mm, Unbreakable Handle	AKT3
			4 mm, 175 x 100 mm, Unbreakable Handle	AKT4
			5 mm, 175 x 100 mm, Unbreakable Handle	AKT5
			6 mm, 205 x 122 mm, Unbreakable Handle	AKT6
			8 mm, 205 x 122 mm, Unbreakable Handle	AKT8
3	T - Allen Key Pro series		1.5 mm, Length 120 mm	AKT15P
			2 mm, Length 120 mm	AKT2P
			2.5 mm, Length 120 mm	AKT25P
			3 mm, Length 120 mm	AKT3P
			4 mm, Length 130 mm	AKT4P
			5 mm, Length 130 mm	AKT5P
			6 mm, Length 150 mm	AKT6P
4	T - Allen Key Supported		1.5 mm, Length 100 mm	AKT15S
			2 mm, Length 100 mm	AKT2S
			2.5 mm, Length 100 mm	AKT25S
			3 mm, Length 100 mm	AKT3S
			4 mm, Length 100 mm	AKT4S
			5 mm, Length 100 mm	AKT5S
			6 mm, Length 200 mm	AKT6S
			8 mm, Length 200 mm	AKT8S
			10 mm, Length 200 mm	AKT10S



5	T - Allen Key Supported - 350 mm Long		2.5 mm, Length 350 mm	AKT25S/35
			3 mm, Length 350 mm	AKT3S/35
			4 mm, Length 350 mm	AKT4S/35
			5 mm, Length 350 mm	AKT5S/35
			6 mm, Length 350 mm	AKT6S/35
			8 mm, Length 350 mm	AKT8S/35
			10 mm, Length 350 mm	AKT10S/35
			6	T - Allen Key Supported - 600 mm Long
4 mm, Length 600 mm	AKT4S/60			
5 mm, Length 600 mm	AKT5S/60			
6 mm, Length 600 mm	AKT6S/60			
8 mm, Length 600 mm	AKT8S/60			
10 mm, Length 600 mm	AKT10S/60			
7	Angle Finder		4", With Magnetic Base	AF-4
8	Armature Bearing Puller		19 to 35mm	ABP19-35
			25 to 75mm	ABP25-75
9	Baby Vice - Clamp Type		32mm, 1 1/4"	BVC-32
			40mm, 1 1/2"	BVC-40
			50mm, 2"	BVC-50
			60mm, 2 1/2"	BVC-60
			75mm, 3"	BVC-75
			100mm, 4"	BVC-100
10	Baby Vice - Clamp Type (Revolving)		Revolving, 32mm, 1 1/4"	BVC-32R
			Revolving, 40mm, 1 1/2"	BVC-40R
			Revolving, 50mm, 2"	BVC-50R
			Revolving, 60mm, 2 1/2"	BVC-60R
			Revolving, 75mm, 3"	BVC-75R

11	Baby Vice - Fixed Base		32mm, 1 1/4"	BVF-32
			40mm, 1 1/2"	BVF-40
			50mm, 2"	BVF-50
			60mm, 2 1/2"	BVF-60
			75mm, 3"	BVF-75
12	Baby Vice - Swivel Base		32mm, 1 1/4"	BVS-32
			40mm, 1 1/2"	BVS-40
			50mm, 2"	BVS-50
			60mm, 2 1/2"	BVS-60
			75mm, 3"	BVS-75
13	Bearing Puller Inter Changeable Hard Tip		4" 2 Jaws, Heavy duty, Interchangeable Hard Tip	BPU-4-2
			6" 2 Jaws, Heavy duty, Interchangeable Hard Tip	BPU-6-2
			8" 2 Jaws, Heavy duty, Interchangeable Hard Tip	BPU-8-2
			10" 2 Jaws, Heavy duty, Interchangeable Hard Tip	BPU-10-2
			4" 3 Jaws, Heavy duty, Interchangeable Hard Tip	BPU-4-3
			6" 3 Jaws, Heavy duty, Interchangeable Hard Tip	BPU-6-3
			8" 3 Jaws, Heavy duty, Interchangeable Hard Tip	BPU-8-3
			10" 3 Jaws, Heavy duty, Interchangeable Hard Tip	BPU-10-3
14	Bearing Puller - Self Centering (SKF Type)		6" x 2 Jaw, 25 to 170 mm, Black Oxide Coated	BPUSC-6-2
			6" x 3 Jaw, 25 to 170 mm, Black Oxide Coated	BPUSC-6-3
15	Bench Vice		Cross Ribbed, Unbrakable, SG Iron body. Extra Heavy Duty 3" - 5.5 Kgs., 4" - 9.5 Kgs., 5" - 14 Kgs., 6" - 18.5 Kgs., 8" - 31 Kgs.	BEV-3
				BEV-4
				BEV-5
				BEV-6
				BEV-8
16	C - Clamp		Drop Forged - 2"	CC-02
			Drop Forged - 3"	CC-03
			Drop Forged - 4"	CC-04
			Drop Forged - 6".	CC-06

16	C - Clamp		Drop Forged - 8"	CC-08
			Drop Forged - 10"	CC-10
			Drop Forged - 12"	CC-12
			Drop Forged - 14"	CC-14
			Drop Forged - 16"	CC-16
17	Case Opener		3", CO3	CO-3
18	Center Punch - Automatic		5" Length	PUA-05
19	Center Punch - Hex		1/8"	PUHX-018
			5/32"	PUHX-532
			3/16"	PUHX-316
20	Center Punch - Round		1/8"	PUR-018
			5/32"	PUR-532
			3/16"	PUR-316
21	Nail Punch Set		3 Pcs, (1/8", 5/32", 3/16")	PUN-3S
22	Nail Punch Square Head		1/8"	PUN-018
			5/32"	PUN-532
			3/16"	PUN-316
23	Pin Punch Round		6" Long, 1/16" Dia, Round Shank	PPUR-116
			6" Long, 3/32" Dia, Round Shank	PPUR-332
			6" Long, 1/8" Dia, Round Shank	PPUR-018
			6" Long, 5/32" Dia, Round Shank	PPUR-532
			6" Long, 3/16" Dia, Round Shank	PPUR-316

23	Pin Punch Round		6" Long, 7/32" Dia, Round Shank	PPUR-732
			6" Long, 1/4" Dia, Round Shank	PPUR-014
			6" Long, 5/16" Dia, Round Shank	PPUR-516
			6" Long, 3/8" Dia, Round Shank	PPUR-038
24	Pin Punch- Drive		8" Long, 1/16" Dia, Round Shank	PPUD-116
			8" Long, 3/32" Dia, Round Shank	PPUD-332
			8" Long, 1/8" Dia, Round Shank	PPUD-018
			8" Long, 5/32" Dia, Round Shank	PPUD-532
			8" Long, 3/16" Dia, Round Shank	PPUD-316
			8" Long, 1/4" Dia, Round Shank	PPUD-014
			8" Long, 5/16" Dia, Round Shank	PPUD-516
			8" Long, 3/8" Dia, Round Shank	PPUD-038
25	Pin Punch Set - Round 6"		9 Pcs, 6" Long (1/16", 3/32", 1/8", 5/32", 3/16", 7/32", 1/4", 5/16", 3/8"), Round Shank	PPUR-9S
26	Pin Punch Set - Drive		8 Pcs, 8" Long (1/16", 3/32", 1/8", 5/32", 3/16", 1/4", 5/16", 3/8"), Round Shank	PPUD-8S
27	Starting Punch		1/8", Hex Shank	PU-S-018
			5/32", Hex Shank	PU-S-532
			3/16", Hex Shank	PU-S-316
			1/4", Hex Shank	PU-S-014
			5/16", Hex Shank	PU-S-516





27	Starting Punch		Set of 5 Pcs, (1/8", 5/32", 3/16", 1/4", 5/16"), Hex Shank	PU-S-5S
28	Hollow Punch		5 mm Dia, Black Phosphate Finished	PUH-5
			6 mm Dia, Black Phosphate Finished	PUH-6
			8 mm Dia, Black Phosphate Finished	PUH-8
			10 mm Dia, Black Phosphate Finished	PUH-10
			12 mm Dia, Black Phosphate Finished	PUH-12
			14 mm Dia, Black Phosphate Finished	PUH-14
			16 mm Dia, Black Phosphate Finished	PUH-16
			18 mm Dia, Black Phosphate Finished	PUH-18
			19 mm Dia, Black Phosphate Finished	PUH-19
			22 mm Dia, Black Phosphate Finished	PUH-22
25 mm Dia, Black Phosphate Finished	PUH-25			
29	Cold Chisel - Octagonal		9 mm x 125 mm, Drop Forged	OCH-9125
			16 mm x 150 mm, Drop Forged	OCH-16150
			22 mm x 200 mm, Drop Forged	OCH-22200
30	Cold Chisel - Flat		20 mm x 150 mm, Drop Forged	FCH-20150
			25 mm x 200 mm, Drop Forged	FCH-25200
31	Cold Chisel - Hexagonal		22 mm x 200 mm, Drop Forged	HX-22200
			25 mm x 250 mm, Drop Forged	HX-25250
32	Combination Plier		8", CrV-3 Material, Extra Heavy Duty	CP-08
33	Cross Wheel Wrench		17x19x21x23mm	XW-17-23





34	Flare Nut Spanner		8 x 10 mm	SPFN-810
			10 x 11 mm	SPFN-1011
			10 x 12 mm	SPFN-1012
			11 x 13 mm	SPFN-1113
			12 x 14 mm	SPFN-1214
			14 x 17 mm	SPFN-1417
			17 x 19 mm	SPFN-1719
			19 x 22 mm	SPFN-1922
			20 x 22 mm	SPFN-2022
			24 x 27 mm	SPFN-2427
			25 x 32 mm	SPFN-2532
			30 x 32 mm	SPFN-3032
			Set of 5 Pcs	SPFN-5S
			35	Halfmoon Spanners Crv
10 x 11 mm	SPHM-1011			
11 x 13 mm	SPHM-1113			
12 x 13 mm	SPHM-1213			
14 x 15 mm	SPHM-1415			
14 x 17 mm	SPHM-1417			
16 x 17 mm	SPHM-1617			
17 x 19 mm	SPHM-1719			
18 x 19 mm	SPHM-1819			
19 x 22 mm	SPHM-1922			
20 x 22 mm	SPHM-2022			
21 x 23 mm	SPHM-2123			
Set of 8 Pcs	SPHM-8S			
36	Ring Spanner			
			34 x 36 mm CrV	SPR-3436
			34 x 38 mm CrV	SPR-3438
			36 x 41 mm CrV	SPR-3641
			41 x 46 mm CrV	SPR-4146
			46 x 50 mm CrV	SPR-4650
			55 x 60 mm CrV	SPR-5560
			65 x 70 mm CrV	SPR-6570
			Set 6 to 22 mm - 8 Pcs CrV	SPR-6/22-8S
			Set 6 to 32 mm - 12 Pcs CrV	SPR-6/32-12S

37

**Single Ended Open Jaw
Spanner**







6 mm	SPS-OJ-06
7 mm	SPS-OJ-07
8 mm	SPS-OJ-08
9 mm	SPS-OJ-09
10 mm	SPS-OJ-10
11 mm	SPS-OJ-11
12 mm	SPS-OJ-12
13 mm	SPS-OJ-13
14 mm	SPS-OJ-14
15 mm	SPS-OJ-15
16 mm	SPS-OJ-16
17 mm	SPS-OJ-17
18 mm	SPS-OJ-18
19 mm	SPS-OJ-19
21 mm	SPS-OJ-21
22 mm	SPS-OJ-22
24 mm	SPS-OJ-24
27 mm	SPS-OJ-27
30 mm	SPS-OJ-30
32 mm	SPS-OJ-32
34 mm	SPS-OJ-34
36 mm	SPS-OJ-36
38 mm	SPS-OJ-38
40 mm	SPS-OJ-40
41 mm	SPS-OJ-41
42 mm	SPS-OJ-42
46 mm	SPS-OJ-46
50 mm	SPS-OJ-50
52 mm	SPS-OJ-52
55 mm	SPS-OJ-55
60 mm	SPS-OJ-60
63 mm	SPS-OJ-63
65 mm	SPS-OJ-65
70 mm	SPS-OJ-70
75 mm	SPS-OJ-75
77 mm	SPS-OJ-77
80 mm	SPS-OJ-80

37	Single Ended Open Jaw Spanner		85 mm	SPS-OJ-85
			88 mm	SPS-OJ-88
			90 mm	SPS-OJ-90
			95 mm	SPS-OJ-95
			100 mm	SPS-OJ-100
			105 mm	SPS-OJ-105
			110 mm	SPS-OJ-110
			115 mm	SPS-OJ-115
			120 mm	SPS-OJ-120
			125 mm	SPS-OJ-125
			130 mm	SPS-OJ-130
38	Slogging Spanner - Open End		27 mm	SLOG-OE-27
			30 mm	SLOG-OE-30
			32 mm	SLOG-OE-32
			41 mm	SLOG-OE-41
			46 mm	SLOG-OE-46
39	Slogging Spanner - Ring End		24 mm	SLOG-RE-24
			30 mm	SLOG-RE-30
			34 mm	SLOG-RE-34
			36 mm	SLOG-RE-36
			38 mm	SLOG-RE-38
			41 mm	SLOG-RE-41
			46 mm	SLOG-RE-46
			50 mm	SLOG-RE-50
			55 mm	SLOG-RE-55
			60 mm	SLOG-RE-60
			65 mm	SLOG-RE-65
40	T - Spanner		6 mm	SPT-06
			7 mm	SPT-07
			8 mm	SPT-08
			9 mm	SPT-09
			10 mm	SPT-10
			11 mm	SPT-11
			12 mm	SPT-12
			13 mm	SPT-13
14 mm	SPT-14			



40	T - Spanner		15 mm	SPT-15
			16 mm	SPT-16
			17 mm	SPT-17
			18 mm	SPT-18
			19 mm	SPT-19
41	Tubular Spanner		6 x 7 mm	SPTU-67
			8 x 9 mm	SPTU-89
			10 x 11 mm	SPTU-1011
			12 x 13 mm	SPTU-1213
			14 x 15 mm	SPTU-1415
			16 x 17 mm	SPTU-1617
			18 x 19 mm	SPTU-1819
			20 x 22 mm	SPTU-2022
			21 x 23 mm	SPTU-2123
			24 x 26 mm	SPTU-2426
			25 x 28 mm	SPTU-2528
			30 x 32 mm	SPTU-3032
			6 to 32 mm, 12 Pcs Set	
6 to 22 mm, 8 Pcs Set			SPTU-6/22-8S	
42	Oil Filter Wrench		60-73 mm, Swivel Handle, Heavy Duty	OFW-6073
			73-85 mm, Swivel Handle, Heavy Duty	OFW-7385
			85-95 mm, Swivel Handle, Heavy Duty	OFW-8595
			95-110 mm, Swivel Handle, Heavy Duty	OFW-95110
43	One For All Wrench		8 to 22 mm, Crv steel	OAW-822
44	Quick Hold Wrench		8 to 22 mm, Crv Steel, Soft Hand Grip	QHW-822



45	Diagonal Cutting Plier		6", CrV-3 Material, Extra Heavy Duty	DCP-06
46	Drill Vice - Uni Grip		3"	DVUG-3
			4" 3 Way	DVUG-4-3
			4"	DVUG-4
			5"	DVUG-5
47	Engineers Stethoscope		12" x 1/4"	ESC-12-14
48	Grease Gun		200CC	GG-200
			300CC	GG-300
			500CC	GG-500
49	Grease Gun Extension - Hose		12"/300 mm Long	GGH-12-300
			18"/450 mm Long	GGH-18-450
50	Grease Nipple		45° Bent Type, 60 mm Long, 12 mm Hex Collar	GNB-60/12
			Straight Type, 60 mm Long, 12 mm Hex Collar	GNS-60/12
			Male Ended, 40 mm Long	GNM-40
			Female Ended, 40 mm Long	GNFM-40
51	Grease Nipple - Adoptor/Hydraulic		15 mm Ø, 4 Jaw, 15 mm Hex Collar	GNAH-15
			17 mm Ø, 4 Jaw, 17 mm Hex Collar	GNAH-17
			19 mm Ø, 4 Jaw, 19 mm Hex Collar	GNAH-19
			Female Ended, 19 mm Long	GNAH-FM-19
			Male Ended, 19 mm Long	GNAH-M-19
52	Hacksaw Frame		HS-02 Pistol Grip, Plastic Handle, Tabular Frame	HS-02
			HS-03 Pistol Grip Diecast Alu Handle, Tabular Frame	HS-03



52	Hacksaw Frame		HS-04 ProSeries, Pistol Grip, Bottom Tensioner	HS-04
			HS-06 Tabular Frame With Ergo Handle	HS-06
53	File Handle - Wood		3"	FHW-03
			4"	FHW-04
			5"	FHW-05
			6"	FHW-06
54	File Handle-Plastic		3" for files of size 6" and 4"	FHP-03
			4" for files of size 10" and 8"	FHP-04
			5" for files of size 14" and 12"	FHP-05
55	Hammer Handle - Nylon Hammer		30 mm (1 1/4"), Ash Wood	XP-30H
			40mm (1 1/2"), Ash Wood	XP-40H
			50mm (2"), Ash Wood	XP-50H
56	Impact Bit - Long		PH2-2 Nos, PH3-2Nos, S2 Material, Copper Brown Finish	IB-1L
			PH2-4 Nos, S2 Material, Copper Brown Finish	IB-2L
			PH3-4 Nos, S2 Material, Copper Brown Finish	IB-3L
			PH2-1 No, PH3-1 No, 8 mm Flat-1 No, 10 mm Flat - 1 No, S2 Material, Copper Brown Finish	IB-4L
57	Impact Bit - Short		PH2-2 Nos, PH3-2 Nos, S2 Material, Copper Brown Finish	IB-1S
			PH2-4 Nos, S2 Material, Copper Brown Finish	IB-2S
			PH3-4 Nos, S2 Material, Copper Brown Finish	IB-3S
			PH2-1 No, PH3-1 No, 8 mm Flat - 1 No, 10 mm Flat - 1 No, S2 Material, Copper Brown Finish	IB-4S

58	Leather Gloves		14" Thick Split Leather with Flannel Lining, Orange Color	LG-14-OR
			14" Thick Split Leather with Flannel Lining, Natural Color	LG-14-NL
59	Line Tester		Cellulose Acetate handle with high quality	LT-100
60	Long Nose Plier		6" CrV-3 Material, Extra Heavy Duty	LNP-06
61	Oil Can		1/2 Pint	OC-50
			1/4 Pint	OC-25
62	Paint Scraper		1" Width, 0.6 mm Thickness, Stainless 420	PSC-01
			1.5" Width, 0.6 mm Thickness, Stainless 420	PSC-15
			2" Width, 0.6 mm Thickness, Stainless 420	PSC-02
			3" Width, 0.6 mm Thickness, Stainless 420	PSC-03
			4" Width, 0.6 mm Thickness, Stainless 420	PSC-04
			5" Width, 0.6 mm Thickness, Stainless 420	PSC-05
			6" Width, 0.6 mm Thickness, Stainless 420	PSC-06
63	Paint Scraper		3" Multi Functional 9 in 1, 1.0 mm Thickness, Stainless 420	PSCM-03

64	PCB Drill		Aluminium Body	PCBD-01
65	Pickup Tool - With Torch		750 mm Telescopic Extension, 1 Super Bright LED, PVC Handle	PTL-75
66	Pipe Wrench - Rigid Type Heavy Duty (New High Torque - CrV)		14" New High Torque Model, CrV Jaws, GT Model	PW20714
			18" New High Torque Model, CrV Jaws, GT Model	PW20718
			24" New High Torque Model, CrV Jaws, GT Model	PW20724
67	Pipe Wrench - Rigid Type Heavy Duty CrV		12" Heavy Duty, CrV Jaws, GT Model	PW20512
			14" Heavy Duty, CrV Jaws, GT Model	PW20514
			18" Heavy Duty, CrV jaws, GT Model	PW20518
			24" Heavy Duty, CrV Jaws, GT Model	PW20524
			36" Heavy Duty, CrV Jaws, GT Model	PW20536
			48" Heavy Duty, CrV Jaws, GT Model	PW20548
	Pipe Wrench - Rigid Type Heavy Duty - Aluminium		24" Light Weight, CrV Jaws, GT Model	PW21724
			36" Light Weight, CrV Jaws, GT Model	PW21736
			48" Light Weight, CrV Jaws, GT Model	PW21748
68	Pop Riveter		Heavy Duty, 3/32", 1/8", 5/32", 3/16" Rivets	PR-01-H
			Free Section type, 3/32", 1/8", 5/32", 3/16" Rivets	PR-02-F

69	Pop Riveter		Professional type, 3/32", 1/8", 5/32", 3/16" Rivets	PR-03-P
			Stainless Steel type, 1/8", 5/32", 3/16" Rivets	PR-04-SS
			Lazy Tone type, 3/32", 1/8", 5/32", 3/16" Rivets	PR-05-LT
			Scissor Action type, 1/8", 5/32", 3/16", 1/4" Rivets	PR-06-SA
			Lever type, 1/8", 5/32", 3/16", 1/4" Rivets	PR-07-LV
			3/32", 1.8", 5/32" Rivets	PR-08
			70	Rubber Mallets
50mm Dia, 140 gms, Nitrile Rubber, ASH wood Handle	RM-140			
60mm Dia, 260 gms, Nitrile Rubber, ASH wood Handle	RM-260			
70mm Dia, 400 gms, Nitrile Rubber, ASH wood Handle	RM-400			
80mm dia, 620 gms, Nitrile Rubber,ASH wood Handle	RM-620			
71	Socket - 1" sq.Drive		18 mm Hi Impact Blackseries	DS1-18
			19 mm Hi Impact Blackseries	DS1-19
			20 mm Hi Impact Blackseries	DS1-20
			21 mm Hi Impact Blackseries	DS1-21
			22 mm Hi Impact Blackseries	DS1-22
			23 mm Hi Impact Blackseries	DS1-23
			24 mm Hi Impact Blackseries	DS1-24
			27 mm Hi Impact Blackseries	DS1-27
			28 mm Hi Impact Blackseries	DS1-28
29 mm Hi Impact Blackseries	DS1-29			





72	Socket - 1" sq.Drive		30 mm Hi Impact Blackseries	DS1-30
			31 mm Hi Impact Blackseries	DS1-31
			32 mm Hi Impact Blackseries	DS1-32
			33 mm hi Impact Blackseries	DS1-33
			34 mm Hi Impact Blackseries	DS1-34
			36 mm Hi Impact Blackseries	DS1-36
			41 mm Hi Impact Blackseries	DS1-41
			42 mm Hi Impact Blackseries	DS1-42
			46 mm Hi Impact Blackseries	DS1-46
			48 mm Hi Impact Blackseries	DS1-48
			50 mm Hi Impact Blackseries	DS1-50
			55 mm Hi Impact Blackseries	DS1-55
			60 mm Hi Impact Blackseries	DS1-60
			65 mm Hi Impact Blackseries	DS1-65
			70 mm Hi Impact Blackseries	DS1-70
			75 mm Hi Impact Blackseries	DS1-75
			80 mm Hi Impact Blackseries	DS1-80
85 mm Hi Impact Blackseries	DS1-85			
90 mm Hi Impact Blackseries	DS1-90			
73	Socket - 1.1/2" sq.Drive		36 mm Hi Impact Blackseries	DS15-36
			38 mm Hi Impact Blackseries	DS15-38
			46 mm Hi Impact Blackseries	DS15-46
			50 mm Hi Impact Blackseries	DS15-50
			60 mm Hi Impact Blackseries	DS15-60
			65 mm Hi Impact Blackseries	DS15-65
			70 mm Hi Impact Blackseries	DS15-70
			75 mm Hi Impact Blackseries	DS15-75
			80 mm Hi Impact Blackseries	DS15-80
			85 mm Hi Impact Blackseries	DS15-85
			90 mm Hi Impact Blackseries	DS15-90
			95 mm Hi Impact Blackseries	DS15-95
			100 mm Hi Impact Blackseries	DS15-100
			105 mm Hi Impact Blackseries	DS15-105
			110 mm Hi Impact Blackseries	DS15-110
115 mm Hi Impact Blackseries	DS15-115			
120 mm Hi Impact Blackseries	DS15-120			



74	Socket - 1/2" sq.Drive		5 mm Hi Impact Blackseries	DS05-5			
			6 mm Hi Impact Blackseries	DS05-6			
			7 mm Hi Impact Blackseries	DS05-7			
			8 mm Hi Impact Blackseries	DS05-8			
			9 mm Hi Impact Blackseries	DS05-9			
			10 mm Hi Impact Blackseries	DS05-10			
			11 mm Hi Impact Blackseries	DS05-11			
			12 mm Hi Impact Blackseries	DS05-12			
			13 mm Hi Impact Blackseries	DS05-13			
			14 mm Hi Impact Blackseries	DS05-14			
			15 mm Hi Impact Blackseries	DS05-15			
			16 mm Hi Impact Blackseries	DS05-16			
			17 mm Hi Impact Blackseries	DS05-17			
			18 mm Hi Impact Blackseries	DS05-18			
			19 mm Hi Impact Blackseries	DS05-19			
			20 mm Hi Impact Blackseries	DS05-20			
			21 mm Hi Impact Blackseries	DS05-21			
			22 mm Hi Impact Blackseries	DS05-22			
			75	Socket - 1/2" sq.Drive		23 mm Hi Impact Blackseries	DS05-23
						24 mm Hi Impact Blackseries	DS05-24
						25 mm Hi Impact Blackseries	DS05-25
						26 mm Hi Impact Blackseries	DS05-26
27 mm Hi Impact Blackseries	DS05-27						
28 mm Hi Impact Blackseries	DS05-28						
29 mm Hi Impact Blackseries	DS05-29						
30 mm Hi Impact Blackseries	DS05-30						
31 mm Hi Impact Blackseries	DS05-31						
32 mm Hi Impact Blackseries	DS05-32						
76	Socket - 3/4" sq.Drive		34 mm Hi Impact Blackseries	DS05-34			
			14 mm Hi Impact Blackseries	DS75-14			
			17 mm Hi Impact Blackseries	DS75-17			
			18 mm Hi Impact Blackseries	DS75-18			
			19 mm Hi Impact Blackseries	DS75-19			
			20 mm Hi Impact Blackseries	DS75-20			
			21 mm Hi Impact Blackseries	DS75-21			
			22 mm Hi Impact Blackseries	DS75-22			
			23 mm Hi Impact Blackseries	DS75-23			
			24 mm Hi Impact Blackseries	DS75-24			
25 mm Hi Impact Blackseries	DS75-25						
26 mm Hi Impact Blackseries	DS75-26						
27 mm Hi Impact Blackseries	DS75-27						





77	Socket - 3/4" sq.Drive		28 mm Hi Impact Blackseries	DS75-28
			29 mm Hi Impact Blackseries	DS75-29
			30 mm Hi Impact Blackseries	DS75-30
			31 mm Hi Impact Blackseries	DS75-31
			32 mm Hi Impact Blackseries	DS75-32
			33 mm Hi Impact Blackseries	DS75-33
			34 mm Hi Impact Blackseries	DS75-34
			36 mm Hi Impact Blackseries	DS75-36
			38 mm Hi Impact Blackseries	DS75-38
			41 mm Hi Impact Blackseries	DS75-41
			46 mm Hi Impact Blackseries	DS75-46
			50 mm Hi Impact Blackseries	DS75-50
			55 mm Hi Impact Blackseries	DS75-55
			60 mm Hi Impact Blackseries	DS75-60
			65 mm Hi Impact Blackseries	DS75-65
			70 mm Hi Impact Blackseries	DS75-70
78	Socket - 3/8" sq.Drive		3 mm Hi Impact Blackseries	DS375-3
			4 mm Hi Impact Blackseries	DS375-4
			5 mm Hi Impact Blackseries	DS375-5
			6 mm Hi Impact Blackseries	DS375-6
			7 mm Hi Impact Blackseries	DS375-7
			8 mm Hi Impact Blackseries	DS375-8
			9 mm Hi Impact Blackseries	DS375-9
			10 mm Hi Impact Blackseries	DS375-10
			11 mm Hi Impact Blackseries	DS375-11
			12 mm Hi Impact Blackseries	DS375-12
			13 mm Hi Impact Blackseries	DS375-13
			14 mm Hi Impact Blackseries	DS375-14
			15 mm Hi Impact Blackseries	DS375-15
			16 mm Hi Impact Blackseries	DS375-16
			17 mm Hi Impact Blackseries	DS375-17
			18 mm Hi Impact Blackseries	DS375-18
19 mm Hi Impact Blackseries	DS375-19			
20 mm Hi Impact Blackseries	DS375-20			
21 mm Hi Impact Blackseries	DS375-21			
22 mm Hi Impact Blackseries	DS375-22			
79	Socket Adaptor		1" F x 1.1/2" M Hi Impact Blackseries	DSA1F15M
			1" F x 3/4" M Hi Impact Blackseries	DSA1F75M
			1.1/2" F x 1" M Hi Impact Blackseries	DSA15F1M
			1.1/2" F x 2.1/2" M Hi Impact Blackseries	DSA15F25M
			1/2" F x 1/4" M Hi Impact Blackseries	DSA05F25M

79	Socket Adaptor		1/2" F x 3/4" M Hi Impact Blackseries	DSA05F75M
			1/2" F x 3/8" M Hi Impact Blackseries	DSA05F375M
			1/4" F x 3/8" M Hi Impact Blackseries	DSA25F375M
			3/4" F x 1" M Hi Impact Blackseries	DSA75F1M
			3/4" F x 3/8" M Hi Impact Blackseries	DSA75F375M
			3/8" F x 1/2" M Hi Impact Blackseries	DSA375F05M
			3/8" F x 1/4" M Hi Impact Blackseries	DSA375F25M
			3/4" F x 1/2" M Hi Impact Blackseries	DSA75F05M
80	Allen Socket - 1" Sq.Drive		17 mm Hi Impact Blackseries, 100 mm OAL	DAS-117
			19 mm Hi Impact Blackseries, 107 mm OAL	DAS-119
			22 mm Hi Impact Blackseries, 112 mm OAL	DAS-122
			24 mm Hi Impact Blackseries, 120 mm OAL	DAS-124
			27 mm Hi Impact Blackseries, 120 mm OAL	DAS-127
			30 mm Hi Impact Blackseries, 120 mm OAL	DAS-130
			32 mm Hi Impact Blackseries, 120 mm OAL	DAS-132
			36 mm Hi Impact Blackseries, 120 mm OAL	DAS-136
81	Allen Socket - 1/2" Sq.Drive		6 mm Hi Impact Blackseries	DAS05-6
			8 mm Hi Impact Blackseries	DAS05-8
			10 mm Hi Impact Blackseries	DAS05-10
			12 mm Hi Impact Blackseries	DAS05-12
			13 mm Hi Impact Blackseries	DAS05-13
			14 mm Hi Impact Blackseries	DAS05-14
			17 mm Hi Impact Blackseries	DAS05-17
			19 mm Hi Impact Blackseries	DAS05-19
82	Allen Socket - 1/4" sq.Drive		3 mm Hi Impact Blackseries	DAS25-3
			4 mm Hi Impact Blackseries	DAS25-4
			5 mm Hi Impact Blackseries	DAS25-5
			6 mm Hi Impact Blackseries	DAS25-6
			8 mm Hi Impact Blackseries	DAS25-8
			10 mm Hi Impact Blackseries	DAS25-10
83	Allen Socket - 3/4" Sq.Drive		12 mm Hi Impact Blackseries	DAS75-12
			14 mm Hi Impact Blackseries	DAS75-14
			18 mm Hi Impact Blackseries	DAS75-18
			19 mm Hi Impact Blackseries	DAS75-19
			20 mm Hi Impact Blackseries	DAS75-20
			22 mm Hi Impact Blackseries	DAS75-22
24 mm Hi Impact Blackseries	DAS75-24			

84	Allen Socket - 3/8" sq.Drive		3 mm Hi Impact Blackseries	DAS375-3
			4 mm Hi Impact Blackseries	DAS375-4
			5 mm Hi Impact Blackseries	DAS375-5
			6 mm Hi Impact Blackseries	DAS375-6
			8 mm Hi Impact Blackseries	DAS375-8
			10 mm Hi Impact Blackseries	DAS375-10
85	Extension Bar - 1" sq.Drive		4" Hi Impact Blackseries	DEB1-4
			5" Hi Impact Blackseries	DEB1-5
			8" Hi Impact Blackseries	DEB1-8
			10" Hi Impact Blackseries	DEB1-10
			12" Hi Impact Blackseries	DEB1-12
			16" Hi Impact Blackseries	DEB1-16
			20" Hi Impact Blackseries	DEB1-20
86	Extension Bar - 1/2" sq.Drive		2", Hi Torque Blackseries	DEB05-2
			3", Hi Torque Blackseries	DEB05-3
			5", Hi Torque Blackseries	DEB05-5
			10", Hi Torque Blackseries	DEB05-10
87	Extension Bar - 1/4" sq.Drive		3" Hi Impact Blackseries	DEB25-3
			5" Hi Impact Blackseries	DEB25-5
			8" Hi Impact Blackseries	DEB25-8
88	Extension Bar - 3/4" sq.Drive		10", Hi Torque Blackseries	DEB75-10
			17", Hi Torque Blackseries	DEB75-17
89	Extension Bar - 3/8" sq.Drive		3" Long Hi Impact Blackseries	DEB375-3
			5" Long Hi Impact Blackseries	DEB375-5
			10" Long Hi Impact Blackseries	DEB375-10
90	Extension Socket - 3/8" sq.Drive		5 mm Hi Impact Blackseries	DES375-5
			8 mm Hi Impact Blackseries	DES375-8
			9 mm Hi Impact Blackseries	DES375-9
			10 mm Hi Impact Blackseries	DES375-10
			11 mm Hi Impact Blackseries	DES375-11
			12 mm Hi Impact Blackseries	DES375-12
			13 mm Hi Impact Blackseries	DES375-13
			14 mm Hi Impact Blackseries	DES375-14
			15 mm Hi Impact Blackseries	DES375-15
16 mm Hi Impact Blackseries	DES375-16			

90	Extension Socket - 3/8" sq.Drive		17 mm Hi Impact Blackseries	DES375-17
			18 mm Hi Impact Blackseries	DES375-18
			19 mm Hi Impact Blackseries	DES375-19
			20 mm Hi Impact Blackseries	DES375-20
			21 mm Hi Impact Blackseries	DES375-21
			22 mm Hi Impact Blackseries	DES375-22
			24 mm Hi Impact Blackseries	DES375-24
91	L - Handle - 1/2" sq.Drive		8", 56 mm x 190 mm, Hi Torque Blackseries	DLH05-08
			10", 75mm x 250mm, Hi Torque Blackseries	DLH05-10
			12", 75 mm x 300 mm, Hi Torque Blackseries	DLH05-12
92	L - Handle - 3/4" sq.Drive		18", Hi Torque Blackseries	DLH75-18
93	Deep Socket - 1" sq.Drive		19 mm Hi Impact Blackseries	DDS1-19
			22 mm Hi Impact Blackseries	DDS1-22
			24 mm Hi Impact Blackseries	DDS1-24
			26 mm Hi Impact Blackseries	DDS1-26
			27 mm Hi Impact Blackseries	DDS1-27
			30 mm Hi Impact Blackseries	DDS1-30
			32 mm Hi Impact Blackseries	DDS1-32
			33 mm Hi Impact Blackseries	DDS1-33
93	Deep Socket - 1" sq.Drive		36 mm Hi Impact Blackseries	DDS1-36
			41 mm Hi Impact Blackseries	DDS1-41
			46 mm Hi Impact Blackseries	DDS1-46
			50 mm Hi Impact Blackseries	DDS1-50
			55 mm Hi Impact Blackseries	DDS1-55
			60 mm Hi Impact Blackseries	DDS1-60
			65 mm Hi Impact Blackseries	DDS1-65
			70 mm Hi Impact Blackseries	DDS1-70
			75 mm Hi Impact Blackseries	DDS1-75
			80 mm Hi Impact Blackseries	DDS1-80
			85 mm Hi Impact Blackseries	DDS1-85
			90 mm Hi Impact Blackseries	DDS1-90
94	Deep Socket - 1/2" sq.Drive		5 mm Hi Impact Blackseries	DDS05-5
			6 mm Hi Impact Blackseries	DDS05-6
			7 mm Hi Impact Blackseries	DDS05-7
			8 mm Hi Impact Blackseries	DDS05-8
			9 mm Hi Impact Blackseries	DDS05-9
			10 mm Hi Impact Blackseries	DDS05-10

94	Deep Socket - 1/2" sq.Drive		11 mm Hi Impact Blackseries	DDS05-11
			12 mm Hi Impact Blackseries	DDS05-12
			13 mm Hi Impact Blackseries	DDS05-13
			14 mm Hi Impact Blackseries	DDS05-14
			15 mm Hi Impact Blackseries	DDS05-15
			16 mm Hi Impact Blackseries	DDS05-16
			17 mm Hi Impact Blackseries	DDS05-17
			18 mm Hi Impact Blackseries	DDS05-18
			19 mm Hi Impact Blackseries	DDS05-19
			20 mm Hi Impact Blackseries	DDS05-20
			21 mm Hi Impact Blackseries	DDS05-21
			22 mm Hi Impact Blackseries	DDS05-22
			23 mm Hi Impact Blackseries	DDS05-23
			24 mm Hi Impact Blackseries	DDS05-24
			25 mm Hi Impact Blackseries	DDS05-25
			26 mm Hi Impact Blackseries	DDS05-26
			27 mm Hi Impact Blackseries	DDS05-27
			28 mm Hi Impact Blackseries	DDS05-28
			29 mm Hi Impact Blackseries	DDS05-29
			30 mm Hi Impact Blackseries	DDS05-30
32 mm Hi Impact Blackseries	DDS05-32			
34 mm Hi Impact Blackseries	DDS05-34			
95	Deep Socket - 3/4"sq.Drive		14 mm Hi Impact Blackseries	DDS75-14
			17 mm Hi Impact Blackseries	DDS75-17
			18 mm Hi Impact Blackseries	DDS75-18
			19 mm Hi Impact Blackseries	DDS75-19
			20 mm Hi Impact Blackseries	DDS75-20
			22 mm Hi Impact Blackseries	DDS75-22
			23 mm Hi Impact Blackseries	DDS75-23
			24 mm Hi Impact Blackseries	DDS75-24
			25 mm Hi Impact Blackseries	DDS75-25
			26 mm Hi Impact Blackseries	DDS75-26
			28 mm Hi Impact Blackseries	DDS75-28
			29 mm Hi Impact Blackseries	DDS75-29
			30 mm Hi Impact Blackseries	DDS75-30
32 mm Hi Impact Blackseries	DDS75-32			
34 mm Hi Impact Blackseries	DDS75-34			
36 mm Hi Impact Blackseries	DDS75-36			

95	Deep Socket - 3/4"sq.Drive		38 mm Hi Impact Blackseries	DDS75-38
			41 mm Hi Impact Blackseries	DDS75-41
			46 mm Hi Impact Blackseries	DDS75-46
			50 mm Hi Impact Blackseries	DDS75-50
			55 mm Hi Impact Blackseries	DDS75-55
			60 mm Hi Impact Blackseries	DDS75-60
			65 mm Hi Impact Blackseries	DDS75-65
96	Deep Socket - 3/8" sq.Drive		4 mm Hi Impact Blackseries	DDS375-4
			5 mm Hi Impact Blackseries	DDS375-5
			6 mm Hi Impact Blackseries	DDS375-6
			7 mm Hi Impact Blackseries	DDS375-7
			8 mm Hi Impact Blackseries	DDS375-8
			9 mm Hi Impact Blackseries	DDS375-9
			10 mm Hi Impact Blackseries	DDS375-10
			11 mm Hi Impact Blackseries	DDS375-11
			12 mm Hi Impact Blackseries	DDS375-12
			13 mm Hi Impact Blackseries	DDS375-13
			15 mm Hi Impact Blackseries	DDS375-15
			16 mm Hi Impact Blackseries	DDS375-16
			17 mm Hi Impact Blackseries	DDS375-17
			18 mm Hi Impact Blackseries	DDS375-18
19 mm Hi Impact Blackseries	DDS375-19			
20 mm Hi Impact Blackseries	DDS375-20			
21 mm Hi Impact Blackseries	DDS375-21			
22 mm Hi Impact Blackseries	DDS375-22			
97	Nozzle Socket - 1/2" Sq drive		30 mm Hi Impact Blackseries	DNS05-30
			32 mm Hi Impact Blackseries	DNS05-32
98	T - Handle - 1/2" sq.Drive		10", Hi Torque Blackseries	DTH05-10
			12", Hi Torque Blackseries	DTH05-12
99	T - Handle - 3/4" sq.drive		20", Hi Torque Blackseries	DTH75-20

100	Universal Joint		1" sq Hi Torque Blackseries	DUJ-1
			1/2" sq Hi Torque Blackseries	DUJ-05
			3/4" sq Hi Torque Blackseries	DUJ-75
			3/8" sq Hi Torque Blackseries	DUJ-375
101	Soft Blow Hammers (Nylon Tipped)		30 mm (1 1/4"), 370 Gms, Light weight, Ash wood Handle, with replaceable Nylon tips.	XP-30
			40 mm (1 1/2"), 510 Gms, Light weight, Ash wood Handle, with replaceable Nylon tips.	XP-40
			50 mm (2"), 660 Gms, Light weight, Ash wood Handle, with replaceable Nylon tips.	XP-50
			40 mm (1 1/2"), Non Rebound, Steel Handle Rubber grip with replaceable Nylon tips.	NR-40
			50 mm, (2"), Non Rebound, Steel Handle Rubber grip with replaceable Nylon tips.	NR-50
			30 mm, (1 1/4"), Light Weight, Steel Handle Rubber grip with replaceable Nylon tips.	TH-30
			40 mm, (1 1/2"), Light Weight, Steel Handle Rubber grip with replaceable Nylon tips.	TH-40
			50 mm, (2"), Light Weight, Steel Handle Rubber grip with replaceable Nylon tips.	TH-50
			30 mm, (1 1/4"), Heavy Solid Head, Steel Handle rubber grip, with replaceable Nylon tips.	STH-30
			40 mm, (1 1/2"), Heavy Solid Head, Steel Handle rubber grip, with replaceable Nylon tips.	STH-40
			50 mm, (2"), Heavy Solid Head, Steel Handle rubber grip, with replaceable Nylon tips.	STH-50
			30 mm, (1 1/4"), Ex Heavy Duty Cast Iron Head, Ash Wood Handle, with replaceable Nylon tips.	CH-30
			40 mm, (1 1/2"), Ex Heavy Duty Cast Iron Head, Ash Wood Handle, with replaceable Nylon tips.	CH-40
			50 mm, (2"), Ex Heavy Duty Cast Iron Head, Ash Wood Handle, with replaceable Nylon tips.	CH-50
		102	Soft Blow Hammers (Aluminium Tipped)	
40 mm, Solid Steel Head, Tubular Steel Handle	ALU-40			
50 mm, Solid Steel Head, Tubular Steel Handle	ALU-50			

103	Spare Tip For Nylon Hammer		30 mm (1 1/4")	XPT-30
			40 mm (1 1/2")	XPT-40
			50 mm (2")	XPT-50
104	Stainless Steel Tweezer		4 Pcs Set	SSTW-4S
			6 Pcs Set	SSTW-6S
105	Ball Pein Hammer		200 gms, Proseries, Powder Coated Head, wedge secured, Ash wood Handle	BP-200
			300 gms, Proseries, Powder Coated Head, Wedge Secured, Ash wood Handle	BP-300
			500 gms, Proseries, Powder Coated Head, wedge secured, Ash wood Handle	BP-500
			600 gms, Proseries, Powder Coated Head, wedge secured, Ash wood Handle	BP-600
			800 gms, Proseries, Powder Coated Head, wedge secured, Ash wood Handle	BP-800
106	Claw Hammer		08 - OZ (227 gms) Steel Handle; Rubber Grip	CW-08
			12- OZ (340 gms) Steel Handle, Rubber Grip	CW-12
			16 - OZ (453 gms) Steel Handle, Rubber Grip	CW-16
107	Locksmith Hammer		300-Gms ProSeries, Ergo Hickory / ASH Handle	LS-30
			500-Gms ProSeries, Ergo Hickory / ASH Handle	LS-50
			1000-Gms ProSeries, Ergo Hickory / ASH Handle	LS-100
			1500-Gms ProSeries, Ergo Hickory / ASH Handle	LS-150
			2000-Gms ProSeries, Ergo Hickory / ASH Handle	LS-200
108	Sledge Hammer		2-LB ProSeries, Ergo Hickory/ASH Handle	SL-02
			3-LB ProSeries, Ergo Hickory/ASH Handle	SL-03
			4-LB ProSeries, Ergo Hickory/ASH Handle	SL-04
			6-LB ProSeries, Ergo Hickory/ASH Handle	SL-06
			7-LB ProSeries, Ergo Hickory/ASH Handle	SL-07
			8-LB ProSeries, Ergo Hickory/ASH Handle	SL-08
			10-LB ProSeries, Ergo Hickory/ASH Handle	SL-10
			12-LB ProSeries, Ergo Hickory/ASH Handle	SL-12
			14-LB ProSeries; Ergo Hickory/ASH Handle	SL-14

109	Stud Remover		1/2" to 3/4" Heavy Duty	SR-05-75
			1/4" to 1/2" Heavy Duty	SR-25-50
110	Suction Lifter		1 Cup, Heavy Aluminium Die Casted, 60 kg Lifting Capacity, Cup Size 5"	SULA-60
			1 Cup, High Density Unbreakable Industrial Plastic, 50 kg Lifting Capacity, Cup Size 5"	SULP-50
			2 Cups, Heavy Aluminium Die Casted, 110 kg Lifting Capacity, Cup Size 5.2"	SULA-2-110
			2 Cups, High Density Unbreakable Industrial Plastic, 100 kg Lifting Capacity, Cup Size 5"	SULP-2-100
			3 Cups, Heavy Aluminium Die Casted, 210 kg Lifting Capacity, Cup Size 5.2"	SULA-3-210
			3 Cups, High Density Unbreakable Industrial Plastic, 150 kg Lifting Capacity, Cup Size 5"	SULP-3-150
111	Tin Cutter		10" Drop Forged; Heavy Duty; Pro Series	TC-10P
			12" Drop Forged; Heavy Duty; Pro Series	TC-12P
			14" Drop Forged; Heavy Duty; Pro Series	TC-14P
			7", Jewellers, PVC Dip Coated Handle	TC-7J
112	Tool Box		17*9*6.5", Three Compartment, Powder Coated	TB-01
			17*9*9", Five Compartment, Powder Coated	TB-02
113	Tool Organiser		9" x 8", Canvas Material.	TOC-01
114	Tyre Lever Flat Forged		12" Length, 1 1/2" Width, Heavy Duty	TLF-12
			18" Length, 1 1/2" Width, Heavy Duty	TLF-18
			24" Length, 1 1/2" Width, Heavy Duty	TLF-24

115	Tyre Lever-Hexagonal		12" Length, 22mm Hexagonal, Extra Heavy Duty	TLH-12
			16" Length, 22 mm Hexagonal, Extra Heavy Duty	TLH-16
			18" Length, 22mm Hexagonal, Extra Heavy Duty	TLH-18
			24" Length, 22mm Hexagonal, Extra Heavy Duty	TLH-24
116	Vice Grip Plier		Size: 10" Drop forged Chrome Vanadium Steel Jaw. CrV Corrosion resistance nickel chrome coating. Circular jaw specially designed to grip circular object.	VGP-10
117	Water Pump Plier		Size: 10" Drop forged using grade alloy steel. Meets International Standard and Design. Special 9- position gives wide 75mm holding range. 2 colours dipped handle for soft comfort.	WPP-10
118	Wheel Spanner		24 x 27 mm, 16" Length, Black phosphate Coating	WSP-01
			27 x 33 mm, 16" Length, Black Phosphate Coating	WSP-02
			30 x 32 mm, 16" Length, Black Phosphate Coating	WSP-03
			32 x 33 mm, 16" Length, Black Phosphate Coating	WSP-04
			27 x 33 mm, 10" Length, Black Phosphate Coating	WSP-05
119	Wooden Mallet		40mm Dia, 250mm Length, 100gm Weight	WM-40
			50mm Dia, 295mm Length, 200gm Weight	WM-50
			62mm Dia, 330mm Length, 400gm Weight	WM-60
			72mm Dia, 430mm Length, 575gm Weight	WM-70

machine tools accessories



MAGNETIC DIAL STAND

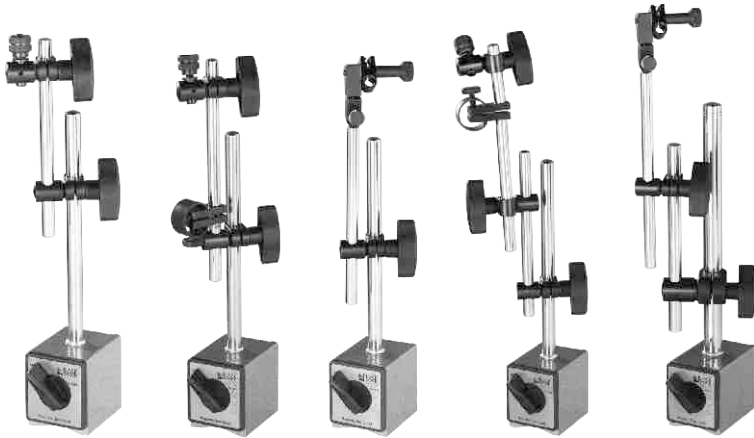

MAGNETIC VEE BLOCK

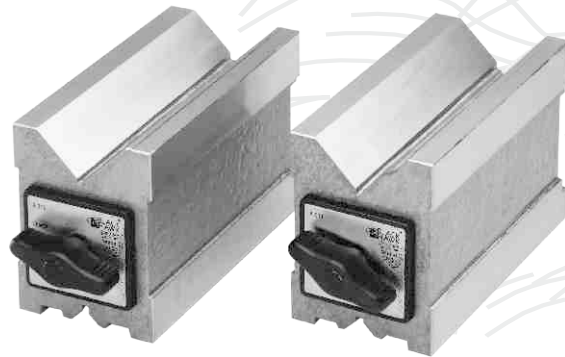

MICRO METER STAND

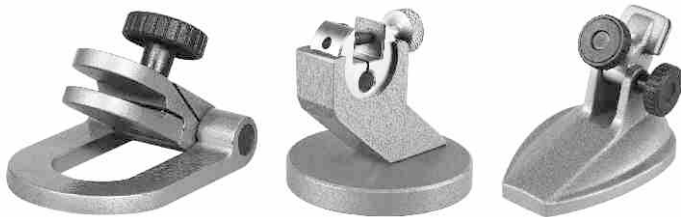

BENCH CENTRE

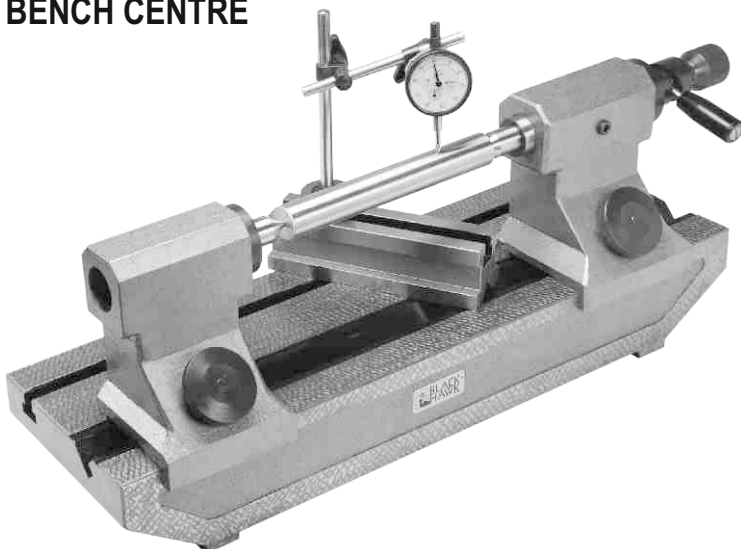

MINI BENCH CENTRE

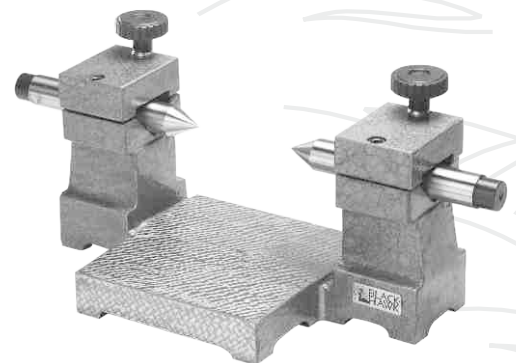

DIAL INDICATOR STAND



LEVELING SCREW JACK - STEEL BODY (Without Pad)



LEVELING SCREW JACK - CI (With Standard Pad)



LEVELING SCREW JACK - PAD



KNURLING CUTTER HOLDERS (Suitable for Rapid & Standard Cutters)



BEARING VEE BLOCK



ANGLE PLATE



Slotted Angle Plate Without Web



Blackhawk Engineering India Pvt. Ltd.,

Orient Estate, 1/10-B, Madukkarai Sundarapuram Road, Coimbatore - 641 021, India
Tel : 0422 - 645 1660, 653 0945, e-mail : sales.blackhawkengg@gmail.com
www.blackhawkengineering.in

TOOL BARS

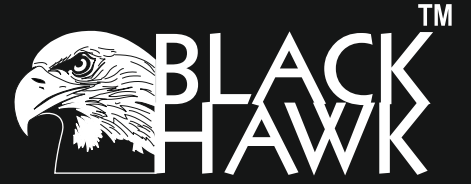

precision professionals

Advantages

Shank Properties

1. Shank is of high quality steel and totally machined - gives consistent quality & performance.
2. Bottom of the shank is precision ground for better vibration resistant contact - which increases possibility for high speed machining with higher speed & field rating.
3. Special high strength alloy silver brazing done at low temperature keeps the properties and structure of the tungsten carbide tip intact.
4. We use high quality tips from the market leaders in the industry.

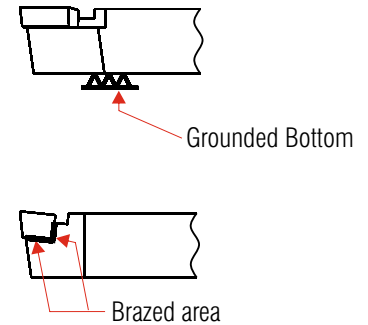

Reading Your Tool Bar

1. The shank have respective colour coding for different grades.
2. Shanks have part number punching for bar identification.

Usage Colour Coding

RED - Cast Iron
 BLUE - Steel
 SILVER - Stainless Steel

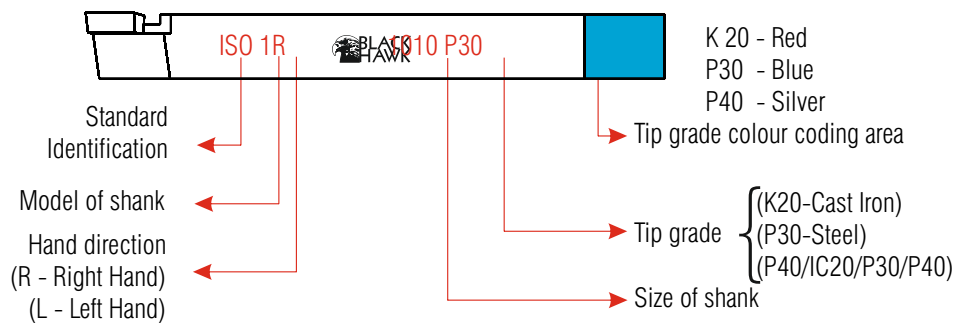

Parting Tool

Unique tip gives added strength for higher feed rates

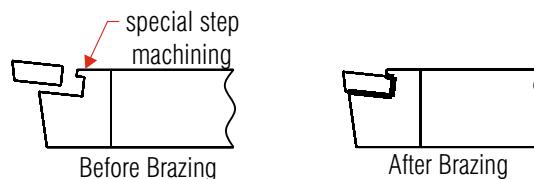

*** The entire process meets stringent quality control.**

Note : Contact us for any special tool requirement in solid, brazed or lugged carbide.

**ISO : 1 (DIN4971)
TURNING TOOL RH/LH**

Size
(mm)

- 1010
- 1212
- 1616
- 2020
- 2525
- 3232
- 4040
- 5050
- 1610
- 2012
- 2516

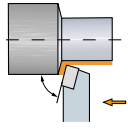

Right hand style shown

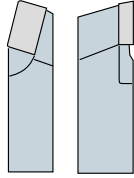

**ISO : 2 (DIN4972)
CR. TURNING &
FACING TOOL RH/LH**

Size
(mm)

- 1010
- 1212
- 1616
- 2020
- 2525
- 3232
- 4040
- 5050
- 1610
- 2012
- 2516

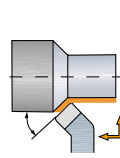

Right hand style shown

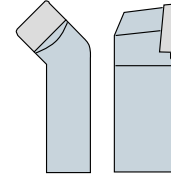

**ISO : 3 (DIN4978)
CR. TURNING &
FACING TOOL RH/LH**

Size
(mm)

- 1010
- 1212
- 1616
- 2020
- 2525
- 3232
- 4040
- 5050
- 1610
- 2012
- 2516

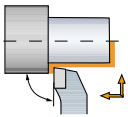

Right hand style shown

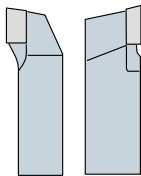

**ISO : 4 (DIN4976)
RECESSING TOOL NH**

Size
(mm)

- 1010
- 1212
- 1616
- 2020
- 2525
- 3232
- 4040
- 5050
- 1610
- 2012
- 2516

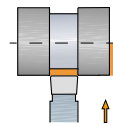

Neutral style shown

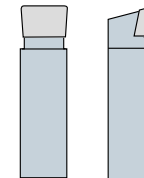

**ISO : 5 (DIN4977)
CRANKED FACING
TOOL RH/LH**

Size
(mm)

- 1010
- 1212
- 1616
- 2020
- 2525
- 3232
- 4040
- 5050
- 1610
- 2012
- 2516

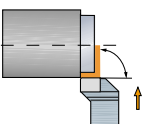

Right hand style shown

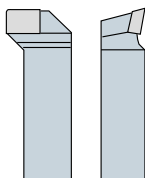

**ISO : 6 (DIN4980)
CRANKED KNIFE
TOOL RH/LH**

Size
(mm)

- 1010
- 1212
- 1616
- 2020
- 2525
- 3232
- 4040
- 5050
- 1610
- 2012
- 2516

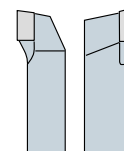
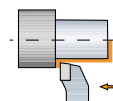

**ISO:7 (DIN4981)
PARTING OFF TOOL RH/LH**

Size
(mm)

1010
1212
1616
2020
2525
3232
1006
1208
1610
2012
2516
3220
4025
5032

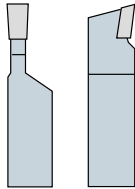
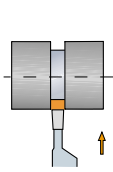

Right hand style shown

**ISO : 8 (DIN4973)
BORING TOOL (SQ.) RH**

Size
(mm)

0808
1010
1212
1616
2020
2525
3232
4040
5050

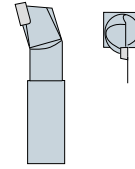
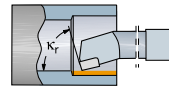

Right hand style shown

**ISO : 9 (DIN4974)
BORING TOOL (RD.) RH**

Size
(mm)

0808
1010
1212
1616
2020
2525
3232

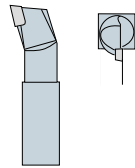
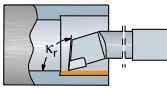

Right hand style shown

**113 - STRAIGHT ROUND NOSE
TURNING TOOL NH**

Size
(mm)

1010
1212
1616
2020
2525
3232
4040
1610
2012
2516
3220
4025
5032

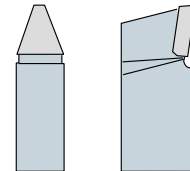
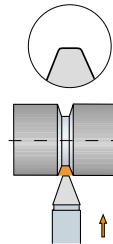

Neutral style shown

**115 - CRANKED ROUND NOSE
TURNING TOOL RH/LH**

Size
(mm)

1010
1212
1616
2020
2525
3232
4040
1610
2012
2516
3220
4025
5032

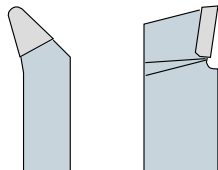
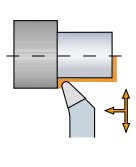

Right hand style shown

**116 - STRAIGHT TURNING TOOL
RH/LH**

Size
(mm)

1010
1212
1616
2020
2525
3232
4040
5050
1610
2012
2516
3220
4025
5032

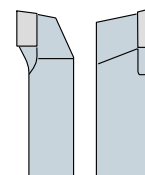
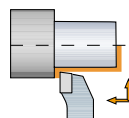

122 - POINTED TURNING TOOL

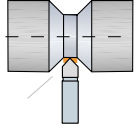

Right hand style shown



Size
(mm)

1010
1212
1616
2020
2525
3232
4040
5050
1610
2012
2516
3220
4025
5032

140 (60°) BORING TOOL RH/L H

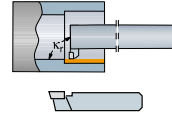

Left hand style shown

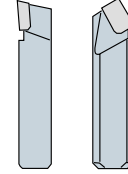

Size	Inch.
6mm	1/4"SC
8mm	5/16"SC
10mm	3/8"
12mm	1/2"
16mm	5/8"
20mm	3/4"
25mm	1"

141 (90°) BORING TOOL RH/L H

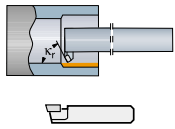

Left hand style shown

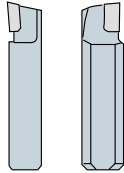

Size	Inch.
6mm	1/4"SC
8mm	5/16"SC
10mm	3/8"
12mm	1/2"
16mm	5/8"
20mm	3/4"
25mm	1"

IND - 2 (60°) EXT. THREADING TOOL RH/LH

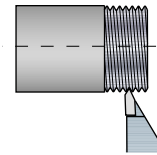

Right hand style shown

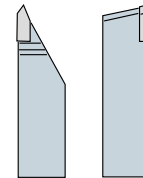

Size (mm)
1010
1212
1616
2020
2525

166 THREADING TOOLS WITH 'V' PROFILE

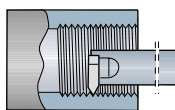

Right hand style shown

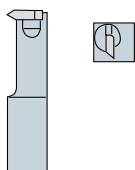

Size
(mm)

1010
1212
1616
2020
2525
3232

163 - STRAIGHT TURNING & GROOVING TOOLS NH

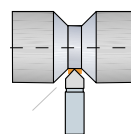

Right hand style shown



Size
(mm)

1010
1212
1616
2020
2525
3232
4040
1610
2012
3220
4025



Blackhawk Engineering India Pvt. Ltd.,

Orient Estate, 1/10-B, Madukkarai Sundarapuram Road, Coimbatore - 641 021, India

Tele : 0422 - 645 1660, Telefax : 0422 - 267 6790

e-mail : blackhawkengg@gmail.com

construction pipe fitting & valves



POLYGON[®]

CERAMIC TILE CUTTERS



The perfect solution for precise cutting

Polygon Ceramic Tile Cutters - Designed and developed to meet the challenges in the tile cutting technology. Adapting the latest methods in aluminum casting, the machines combine aesthetic and ruggedness to give a perfect cutting on ceramic surface. Choosing the ideal raw material for components and strict quality measures have ensured a long life and customer satisfaction. The international design, quality and aesthetics have given the product its due recognition in both India and abroad.

Polygon Tile Cutters are available through a wide Distribution network with excellent after sales support for replacement spares.

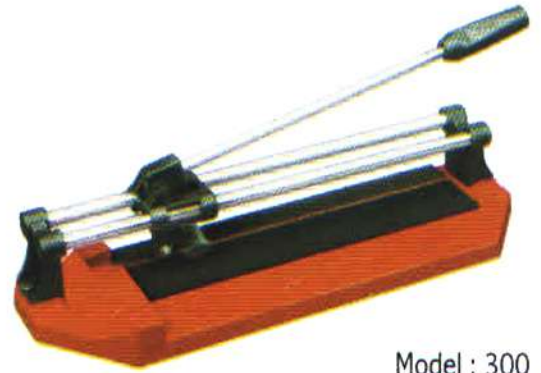

Model : 300

Features

- > Non-rusting aluminium die cast base
- > Powder coated finish in attractive colours
- > Hard chrome plated double barrel movement for smooth operation
- > Self adhesive waterproof polyethylene cross link sheet for better grip
- > Steel insert in breaking area ensures long life and easy breaking
- > High strength tungsten carbide blade
- > Non-metallic glass filled nylon components
- > Clear moulded scale for accurate measurements
- > All parts replaceable

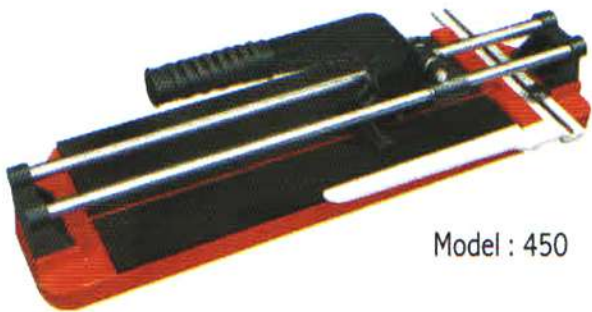

Model : 450



Model : 650

Specification	Model : 300	Model : 450	Model : 650
Straight Cutting Length	12" / 300 mm	18" / 450 mm	24" / 600 mm
Diagonal Cutting Length	8" / 200 mm	12" / 300 mm	18" / 450 mm
Dimension LxBxH	430 x 140 x 110	645 x 195 x 165	875 x 195 x 165
Weight	1.85 Kgs.	5.5 Kgs.	6.5 Kgs.

POLYGON ENGINEERS

E - 46 Sidco Industrial Estate, Coimbatore 641 021, India.

Ph : 0422 267 1085, 657 0004, Fax : 91 - 422 - 267 4774, e-mail : pentool@eth.net



Think.
Fit.
Forget.



Lead Free



Non Welded



Easy to Install



Long Lasting





PIPE ADAPTERS

The Top adaptor is used for connecting topmost column pipe to the discharge fitting / discharge bend.

Available Sizes :

1", 1¼", 1½", 2", 2½", 3" & 4".

Available Grades : SS 316, 304 & 410.



PUMP ADAPTERS

The bottom adaptor is used for connecting submersible pump to the column pipe.

Available Sizes :

1", 1¼", 1½", 2", 2½", 3" & 4".

Available Grades : SS 316, 304 & 410.



REDUCER

Eagle Stainless Steel REDUCERS are designed with square threads to ensure proper gripping and there is no chance of column slippage during installation and removal of pumps. All threads are checked thoroughly with fitment gauges for 100% accuracy.

Available Sizes :

2½" x 2", 2" x 1½", 1½" x 2, 1¼" x 1½", 1½" x 1¼", 1¼" x 1".

Available Grades : SS 316, 304 & 410.

FOOT VALVE



Eagle Stainless Steel FOOT VALVE are designed with latest technology incorporating double guide support for plunger, O-ring is made of Nitrile Rubber, abrasion resistant is precision fitted to the poppet for a positive seal into the tapered (33°) self-cleaning valve. Stainless Steel poppet spring designed for optimum tension ensures power saving. Single piece deep drawn perforated Suction Strainer ensures long life.

All valves ($\frac{3}{4}$ " - 1 $\frac{1}{2}$ ") have a working pressure of 400 psi. Valves above 2" is designed for a working pressure of 600 psi.

Available Sizes :

1", 1 $\frac{1}{4}$ ", 1 $\frac{1}{2}$ ", 2"

Available Grades : SS 316, 304 & 410.

JET ASSEMBLY



Eagle Stainless Steel JET ASSEMBLY are designed with latest technology, the Foot Valve plunger, Stainers are made of quality Stainless Steel with a precision machined finish to meet international standards.

Jet Body & Foot Valve are Casted Stainless Steel, Nozzle made of Forged Brass, Venturi Made of high quality Nylon.

Available Size :

1 $\frac{1}{4}$ " x 1"

Available Grades : SS 316, 304 & 410.



Gowtham posses a rich knowledge and is a leader in the production of intricately shaped Stainless Steel & Steel casted components. We have mastered this technology over a period of 5 decades in combination with metallurgical experience.

In the year 2002, sensing the market requirement we introduced International quality - EAGLE - Pipe Fittings and Valves. Eagle's in house steel casting foundry ensures world class stainless steel moulded products. Backed by a well experienced professionally qualified team, Eagle products undergo stringent quality checks at every stage of production.

Eagle assures :

- High accuracy standards
- Perfect thread dimensions for easy fitment and removal
- Strong threaded joints
- Excellent finish
- Long Life

Eagle products are available in various sizes to suit every application

Eagle products can also be manufactured to suit various Column Pipes available in the International market.

R & D being continuous process specifications are subject to change without prior notice



Manufacturers :

Gowtham Engg. Company

Coimbatore - 641 025, India.

M : + 91 87540 28823, 98422 36081

T : + 91 422 2401361

E : eaglecoimbatore@gmail.com

W : www.eaglepumpguard.com



Sole Distributor for Tamilnadu :

Revathi Enterprises

139, Kalidas Road,

Ramnagar, Coimbatore-641 009.

Tel : 0422 - 2233266 / 2231211

e-mail : revathienter@gmail.com



WATERTEC
- Simply Better -



For leak proof plumbing system always use WATERTEC CPVC Pipes with WATERTEC CPVC Fittings and for joining use solvent cement supplied by WATERTEC.

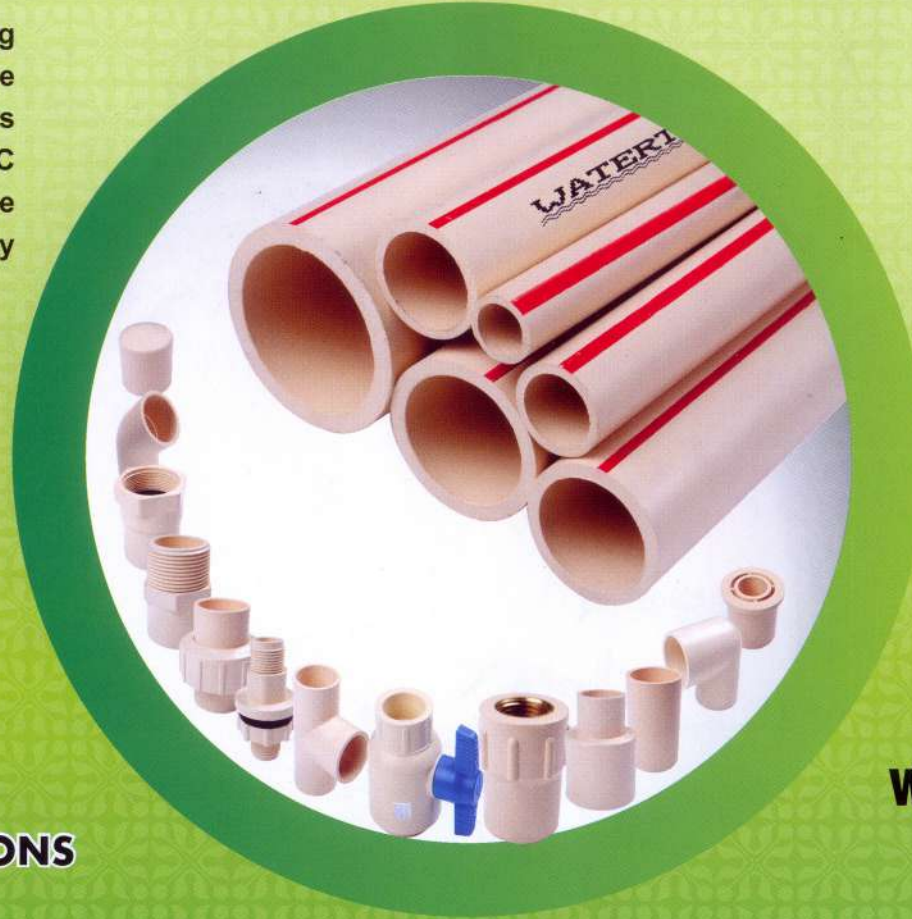

PRICE LIST

w.e.f 1st April, 2014

**IDEAL FOR HOT
AND COLD
WATER APPLICATIONS**

**WORLD CLASS CPVC
PIPES & FITTINGS**

WATERTEC (INDIA) PVT. LTD.

Regd. Office: "Gopal Bagh", 1062, Avinashi Road, Coimbatore – 641 018. INDIA Ph: +91 - 422 - 2243439 (5 Lines), 2245295, 2248851
Fax: 0422:2242760 Email: commercials@watertecindia.com, exports@watertecindia.com Website: www.watertecindia.com



Pipe SDR 11 (Class 1) 3 & 5 mtr. Length (As per IS 15778)

SIZE		Std. Pkg.	Price per Mtr	Price per	
(inch)	(mm)			3 mtr Length	5 mtr Length
½	15	50	66.00	198.00	330.00
¾	20	50	93.00	279.00	465.00
1	25	25	140.00	420.00	700.00
1¼	32	15	224.00	672.00	1120.00
1½	40	10	308.00	924.00	1540.00
2	50	10	515.00	1545.00	2575.00



Pipe SDR 13.5 (Class 2) 3 & 5 mtr. Length (As per IS 15778)

SIZE		Std. Pkg.	Price per Mtr	Price per	
(inch)	(mm)			3 mtr Length	5 mtr Length
½	15	50	56.00	168.00	280.00
¾	20	50	88.00	264.00	440.00
1	25	25	121.00	363.00	605.00
1¼	32	15	185.00	555.00	925.00
1½	40	10	260.00	780.00	1300.00
2	50	10	430.00	1290.00	2150.00

CPVC FITTINGS in SDR 11 as per ASTM D 2846 in CTS (Copper Tube Sizes)



ELBOW 90°					
SIZE		Std. Pkg.	Unit Price	Price per Std. Pkg.	Std. Pkg. per Box
(inch)	(mm)				
½	15	100	12.00	1200.00	10
¾	20	100	15.70	1570.00	6
1	25	50	33.00	1650.00	6
1¼	32	10	60.90	609.00	20
1½	40	10	115.00	1150.00	12
2	50	5	240.80	1204.00	12



TEE					
SIZE		Std. Pkg.	Unit Price	Price per Std. Pkg.	Std. Pkg. per Box
(inch)	(mm)				
½	15	50	15.65	782.50	10
¾	20	50	25.40	1270.00	8
1	25	25	39.65	991.25	8
1¼	32	10	76.60	766.00	15
1½	40	10	141.00	1410.00	8
2	50	5	298.70	1493.50	8



REDUCING MABT (BRASS)					
SIZE		Std. Pkg.	Unit Price	Price per Std. Pkg.	Std. Pkg. per Box
(inch)	(mm)				
¾ X ½	20 X 15	50	94.10	4705.00	20
1 X ½	25 X 15	25	176.40	4410.00	6



THREADED END PLUG					
SIZE		Std. Pkg.	Unit Price	Price per Std. Pkg.	Std. Pkg. per Box
(inch)	(mm)				
½	15	100	6.75	675.00	6



FAPT					
SIZE		Std. Pkg.	Unit Price	Price per Std. Pkg.	Std. Pkg. per Box
(inch)	(mm)				
½	15	50	14.30	715.00	12
¾	20	50	25.30	1265.00	8
1	25	25	35.05	876.25	10
1¼	32	10	83.50	835.00	15
1½	40	10	110.70	1107.00	10
2	50	5	178.00	890.00	10



REDUCING COUPLER					
SIZE		Std. Pkg.	Unit Price	Price per Std. Pkg.	Std. Pkg. per Box
(inch)	(mm)				
¾ X ½	20 X 15	100	14.75	1475.00	5
1 X ¾	25 X 20	50	24.00	1200.00	10
1¼ X ¾	32 X 20	25	52.45	1311.25	8
1¼ X 1	32 X 25	50	57.30	2865.00	5
1½ X 1¼	40 X 32	25	79.35	1983.75	2
1½ X 1	40 X 25	25	86.60	2165.00	2



REDUCING FBT (BRASS)					
SIZE		Std. Pkg.	Unit Price	Price per Std. Pkg.	Std. Pkg. per Box
(inch)	(mm)				
¾ X ½	20 X 15	50	63.30	3165.00	4
1 X ½	25 X 15	25	81.95	2048.75	4



COUPLER SOCKET					
SIZE		Std. Pkg.	Unit Price	Price per Std. Pkg.	Std. Pkg. per Box
(inch)	(mm)				
½	15	100	8.80	880.00	10
¾	20	100	11.55	1155.00	10
1	25	50	21.15	1057.50	10
1¼	32	10	37.00	370.00	30
1½	40	10	69.00	690.00	20
2	50	10	145.00	1450.00	10



FABT (BRASS)					
SIZE		Std. Pkg.	Unit Price	Price per Std. Pkg.	Std. Pkg. per Box
(inch)	(mm)				
½	15	10	111.65	1116.50	20
¾	20	10	153.00	1530.00	15
1	25	5	237.00	1185.00	20
1¼	32	5	499.25	2496.25	8
1½	40	2	576.75	1153.50	10



MAPT					
SIZE		Std. Pkg.	Unit Price	Price per Std. Pkg.	Std. Pkg. per Box
(inch)	(mm)				
½	15	100	10.60	1060.00	8
¾	20	100	18.50	1850.00	8
1	25	50	28.15	1407.50	6
1¼	32	10	42.40	424.00	15
1½	40	10	61.70	617.00	10
2	50	10	122.00	1220.00	5

REDUCING MAPT					
SIZE	Std. Pkg.	Unit Price	Price per Std. Pkg.	Std. Pkg. per Box	
¾ x ½	20x15	100	22.60	2260.00	5



TEE (BRASS)					
SIZE		Std. Pkg.	Unit Price	Price per Std. Pkg.	Std. Pkg. per Box
(inch)	(mm)				
¾ X ¾ X ½	20X20X15	10	63.25	632.50	20
1 X 1 X ½	25X25X15	10	109.00	1090.00	15



END CAP					
SIZE		Std. Pkg.	Unit Price	Price per Std. Pkg.	Std. Pkg. per Box
(inch)	(mm)				
½	15	100	6.50	650.00	10
¾	20	100	11.05	1105.00	5
1	25	100	17.65	1765.00	3
1¼	32	10	33.20	332.00	10
1½	40	10	48.00	480.00	10
2	50	10	104.00	1040.00	5



MABT (BRASS)					
SIZE		Std. Pkg.	Unit Price	Price per Std. Pkg.	Std. Pkg. per Box
(inch)	(mm)				
½	15	10	116.25	1162.50	20
¾	20	10	151.00	1510.00	15
1	25	5	237.00	1185.00	10
1¼	33	5	489.00	2445.00	8
1½	40	2	635.00	1270.00	10



REDUCER TEE					
SIZE		Std. Pkg.	Unit Price	Price per Std. Pkg.	Std. Pkg. per Box
(inch)	(mm)				
¾ x ¾ x ½	20x20x15	50	35.05	1752.50	6
1 x 1 x ¾	25x25x20	25	56.50	1412.50	3
1 ¼ x 1 ¼ x ¾	32x32x20	10	118.15	1181.50	5
1 ¼ x 1 ¼ x 1	32x32x25	10	100.60	1006.00	10
1 ½ x 1 ½ x ¾	40x40x20	10	167.00	1670.00	5
1 ½ x 1 ½ x 1	40x40x25	10	161.70	1617.00	5
1 x 1 x ½	25x25x15	25	53.50	1337.50	8



ELBOW 90° (BRASS)					
SIZE		Std. Pkg.	Unit Price	Price per Std. Pkg.	Std. Pkg. per Box
(inch)	(mm)				
¾ X ½	20 X 15	50	52.85	2642.50	3
1 X ½	25 X 15	25	96.70	2417.50	4



UNION						
SIZE		Std. Pkg.	Unit Price	Price per Std. Pkg.	Std. Pkg. per Box	
(inch)	(mm)					
½	15	10	40.60	406.00	20	
¾	20	10	75.60	756.00	15	
1	25	10	111.50	1115.00	10	
1¼	32	10	131.90	1319.00	8	
1½	40	10	217.00	2170.00	6	
2	50	5	385.60	1928.00	5	



TANK NIPPLE						
SIZE		Std. Pkg.	Unit Price	Price per Std. Pkg.	Std. Pkg. per Box	
(inch)	(mm)					
¾	20	10	46.20	462.00	6	
1	25	10	71.00	710.00	4	
1¼	32	10	113.00	1130.00	3	
1½	40	10	162.00	1620.00	2	
2	50	5	257.00	1285.00	4	



ELBOW 45°						
SIZE		Std. Pkg.	Unit Price	Price per Std. Pkg.	Std. Pkg. per Box	
(inch)	(mm)					
½	15	100	13.85	1385.00	5	
¾	20	100	23.80	2380.00	2	
1	25	50	41.00	2050.00	6	
1¼	32	10	75.60	756.00	6	
1½	40	10	119.95	1199.50	4	
2	50	5	249.00	1245.00	4	



BUSHING						
SIZE		Std. Pkg.	Unit Price	Price per Std. Pkg.	Std. Pkg. per Box	
(inch)	(mm)					
¾ x ½	20 x 15	100	8.35	835.00	10	
1 x ¾	25 x 20	100	13.65	1365.00	6	
1 x ½	25 x 15	100	19.40	1940.00	6	
1¼ x 1	32 x 25	10	22.50	225.00	30	
1¼ x ¾	32 x 20	10	26.90	269.00	30	
1½ x 1¼	40 x 32	10	29.55	295.50	20	
1½ x 1	40 x 25	10	41.70	417.00	20	
1½ x ¾	40 x 20	10	43.00	430.00	20	



CPVC BALL VALVE						
SIZE		Std. Pkg.	Unit Price	Price per Std. Pkg.	Std. Pkg. per Box	
(inch)	(mm)					
¾	20	5	145.00	725.00	10	
1	25	5	267.00	1335.00	10	
1¼	32	5	470.00	2350.00	10	
1½	40	2	736.00	1472.00	5	
2	50	2	1290.00	2580.00	5	



CPVC SOLVENT CEMENT			
SIZE (ml)	Std. Pkg.	Unit Price	Price per Std. Pkg.
15ml (½Oz)	100	61.00	6100.00
29.5ml (1Oz)	64	82.00	5248.00
59ml (2Oz)	40	125.00	5000.00
118ml (4Oz)	24	185.00	4440.00
237ml (8Oz)	24	315.00	7560.00
473ml (16Oz)	12	530.00	6360.00
946ml (32Oz)	6	990.00	5940.00

Branches at :

SOUTH : COIMBATORE : PH: 0422 - 3530433 | CHENNAI : PH: 044 - 32968450 | MADURAI : PH: 0452 - 2609061, 3296845 | TRICHY: PH: 0431 - 2794764, 3254845 | SALEM : PH: 0427 - 2440422, 3918205 | PALAKKAD: PH: 0491 - 2538715, 3297845 | ERNAKULAM : PH: 0484 - 3207845, 2404616 | TRIVANDRUM: PH: 0471 - 3107845, 2575773 | CALICUT : PH: 0495 - 4017845, 2704142 | BANGALORE : PH: 080 - 26742329, 32978450 | MYSORE : PH: 0821 - 2460180, 3209971 | HUBLI : PH: 0836 - 2257707, 3297845 | GOA: PH: 0832 - 2757678 | MANGALORE : PH: 0824 - 2427845, 3207845 | HYDERABAD : PH: 040 - 27702979, 32978450 | VIJAYAWADA : PH: 0866 - 2570758, 3297845 | VISAKHAPATNAM: PH: 0891 - 2721527, 3297845 | **EAST :** KOLKATA : PH: 033 - 64592419, 24235803 | SILIGURI: PH: 0353 - 2540588, 09832044074 | BHUBANESHWAR : PH: 0674 - 2748504, 6574347 | PATNA : PH: 0612 - 3261988, 6532389 | RANCHI : PH: 0651 - 2281309, 6572845 | **WEST :** PUNE : PH: 020 - 64100615, 32677053 | NAGPUR: PH: 9370051155 | AHMEDABAD : PH: 079 - 32446660, 65493136 | INDORE : PH: 0731 - 4071112, 2564635



WATERTEC

- Simply Better -



Taps | Valves | Showers | Faucets | Mixers | Bathroom Accessories | Connection Hoses

NOT JUST PLASTIC, IT IS ENGINEERING POLYMER!

Leak Free

Clog Free

Rust Free



Effective 1st September 2013

WATERTEC (INDIA) PVT. LTD.

Regd. Office: "Gopal Bagh", 1062, Avinashi Road,
Coimbatore - 641 018. INDIA

Ph: +91 - 422 - 2243439 (5 Lines), 2245295, 2248851

Fax: 0422:2242760

E-mail: commercials@watertecindia.com, exports@watertecindia.com

Website: www.watertecindia.com

World Class bathroom fittings and accessories



BIB Tap T	Rs. 138/-	BIB Tap M	Rs. 188/-	BIB Tap M with Flange	Rs. 260/-	2 Way BIB Tap M	Rs. 355/-	Wall sink Tap	Rs. 539/-	180mm Long Body BIB Tap - T Handle	Rs. 209/-
-----------	-----------	-----------	-----------	-----------------------	-----------	-----------------	-----------	---------------	-----------	------------------------------------	-----------

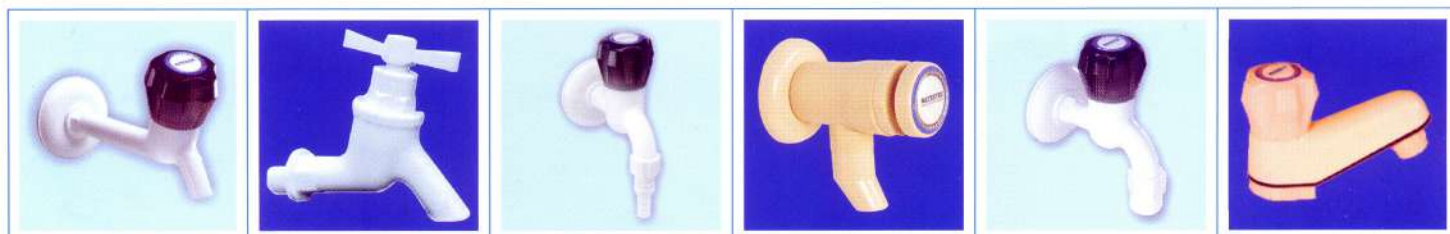

180mm Long Body BIB Tap - M Handle	Rs.278/-	Smart Tap	Rs. 57/-	Garden Tap M Handle	Rs. 271/-	Push Cock	Rs.165/-	Washing Machine Tap	Rs. 301/-	Pillar Tap	Rs. 297/-
------------------------------------	----------	-----------	----------	---------------------	-----------	-----------	----------	---------------------	-----------	------------	-----------



Right angle valve M Handle	Rs. 203/-	Right angle valve T Handle	Rs. 164/-	2 Way Right Angle Valve	Rs.342/-	UPVC Ball Valve 20mm(1/2") to 63mm(2")	Rs.146/- onwards	CPVC - 20mm (3/4") to 50mm (2")	Rs. 123/- onwards	RPVC - 20mm (1/2") to 63 mm (2")	Rs. 59/- onwards
----------------------------	-----------	----------------------------	-----------	-------------------------	----------	--	------------------	---------------------------------	-------------------	----------------------------------	------------------

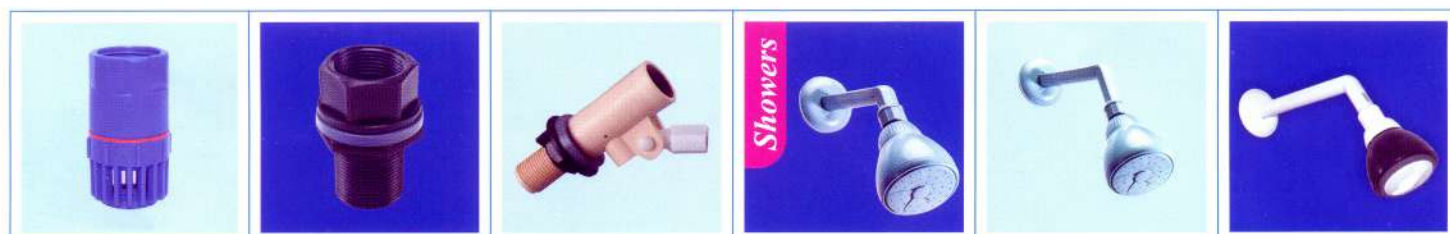

Foot Valve (20mm to 40mm)	Rs. 55/- onwards	Tank Nipple 15, 20, 25 mm	Rs. 48/- onwards	Float valve with Rod & Ball 15mm - 25mm	Rs. 196/- onwards	Shower 5A	Rs.203/-	Shower 8A	Rs. 242/-	Deluxe Adjustable Shower	Rs. 337/-
----------------------------	------------------	---------------------------	------------------	---	-------------------	-----------	----------	-----------	-----------	--------------------------	-----------



Hand Shower	Rs. 453/-	2 in 1 Faucet	1 Mtr Rs. 366/- 1.5 Mtr Rs. 422/-	Wall Mixer Hot & Cold	Rs.1,243/-	Rectangular Mirror	Rs. 887/-	Oval Mirror	Maxi Rs. 796/- Mini Rs. 423/-	Round Mirror	Rs.483/-
-------------	-----------	---------------	--------------------------------------	-----------------------	------------	--------------------	-----------	-------------	----------------------------------	--------------	----------

FEATURES

1. Products made of Virgin grade engineering polymers such as ABS & Poly Acetal, highly durable.
2. Super seal technology capable of withstanding 200,000 cycles, lasting six years and more.
3. Leak free, Drip free & Rust free, Easy to maintain.
4. Can be used for Hot & Cold water applications up to 65°C ± 5°C
5. UV stabilized & Light fast pigments, no fading of colours.
6. Highly polished inner parts reduce wear & tear and also dust / salt sedimentation.
7. All Taps, Valves & Showers are of Standard 1/2" BSP thread.
8. Available in seven attractive colours.



Deck Roll Horizontal	Rs. 1,530/-	Deck Roll Vertical	Rs. 1,684/-	Bathroom Cabinet with Mirror	Rs. 1,622/-	Deluxe Towel Ring	Rs. 142/-	Towel Ring	Rs. 133/-	Towel Holder	Rs. 506/-
----------------------	-------------	--------------------	-------------	------------------------------	-------------	-------------------	-----------	------------	-----------	--------------	-----------



Soap Holder	Rs. 119/-	Double Soap & Tooth Brush Shelf	Rs. 195/-	Toilet Tissue Paper Holder	Rs. 291/-	Bathroom Kit	Rs. 185/-	Vanity Shelf	Rs. 495/-	Deluxe Soap Holder	Rs. 125/-
-------------	-----------	---------------------------------	-----------	----------------------------	-----------	--------------	-----------	--------------	-----------	--------------------	-----------

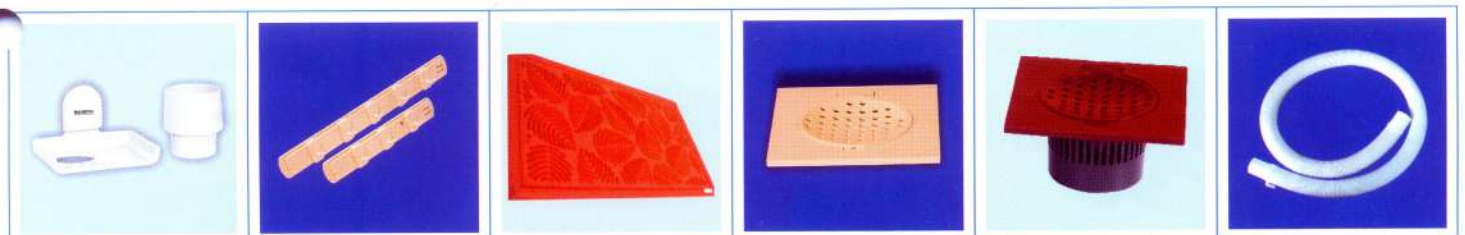

Tooth Brush Holder	Rs. 214/-	Smart Hanger	203mm Rs. 44/- 305mm Rs. 58/-	Insta-Dry Bathroom mat (580mm x 350mm)	Rs. 187/-	Floor Trap	Rs. 93/-	Floor Trap with Grating	Rs. 142/-	Washing Machine outlet pipe	Rs. 114/-
--------------------	-----------	--------------	----------------------------------	--	-----------	------------	----------	-------------------------	-----------	-----------------------------	-----------



Waste Coupling	Rs. 73/-	PVC Waste Pipe 32mm x 750mm	Rs. 135/-	Toilet Seat White Cover	Rs. 465/- Rs. 565/-	Single flush White Cistern	Rs. 1180/- Rs. 1345/-	Dual flush White Cistern	Rs. 1480/- Rs. 1600/-	Bottle Trap	Rs. 321/-
----------------	----------	-----------------------------	-----------	-------------------------	------------------------	----------------------------	--------------------------	--------------------------	--------------------------	-------------	-----------



PVC Connection Tube	Rs. 73/- onwards	Health Faucet	Rs. 444/-	Wall Sink Tap	Rs. 475/-	Hand Shower Circular	Rs. 811/-	Hand Shower Square	Rs. 873/-
---------------------	------------------	---------------	-----------	---------------	-----------	----------------------	-----------	--------------------	-----------

AVAILABLE COLOURS*



White Almond Apricot Burgandy Green L.Blue Charcoal

*The colours shown are indicative only

packing solutions



Protective Sleeves



PP Machine Strap



PET Strap



Speciality Tapes



Cable Ties



Air Bubble Sheet



Masking Tape



Stretch Film



PVC / LD Shrink Film



Polyolefin Film



VCI Film & Paper



Packing Solutions

Band Sealing Machine - Horizontal



Dry Ink Coding Machine



Band Sealing Machine Vertical



Box Strapping Machine



Induction Foil Sealer Portable



Shrink Wrap Chamber



Semi - Auto Shrink Wrap Machine



Tape Dispenser



Hand Sealer



testing & measuring instruments



KENCY™

CATALOGUE



VERNIER CALIPERS



Sl.No.	Measuring Range mm / Inch	L.C.
1	0-150 / 6"	0.02mm
2	0-200 / 8"	0.02mm
3	0-300 / 12"	0.02mm
4	0-600 / 24"	0.02mm
5	0-1000 / 40"	0.02mm
6	0-1500 / 60"	0.02mm
7	0-2000 / 80"	0.02mm
8	0-3000 / 120"	0.02mm

DIGITAL CALIPERS



Sl.No.	Measuring Range mm / Inch	L.C.
1.	0-150 / 6"*	0.01mm
2.	0-200 / 8"*	0.01mm
3.	0-300 / 12"*	0.01mm
4.	0-600 / 24"	0.01mm
5.	0-1000 / 40"	0.01mm
6.	0-1500 / 60"	0.01mm

*(Carbide Tipped also available)

WATER PROOF DIGITAL CALIPER



Sl. No.	Measuring Range mm	L.C.
1.	150	.01
2.	200	.01
3.	300	.01

DIAL CALIPERS



Sl.No.	Measuring Range mm / Inch	L.C.
1.	0-150	0.02mm
2.	0-200	0.02mm
3.	0-300	0.02mm

(0.01mm also available)

VERNIER DEPTH GAGES



Sl.No.	Measuring Range mm / Inch	L.C.
1	0-150 / 6"	0.02mm
2	0-200 / 8"	0.02mm
3	0-300 / 12"	0.02mm

DIGITAL DEPTH VERNIER



Sl.No.	Measuring Range mm / Inch	L.C.
1.	0-150 / 6"	0.01mm
2.	0-200 / 8"	0.01mm
3.	0-300 / 12"	0.01mm
4.	0-600 / 24"	0.01mm

VERNIER DEPTH GAGES HOOK TYPE



Sl.No.	Measuring Range mm / Inch	L.C.
1	0-150 / 6"	0.02mm
2	0-200 / 8"	0.02mm
3	0-300 / 12"	0.02mm

HOOK TYPE DIGITAL DEPTH GAGES

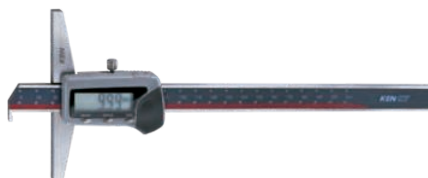

Sl.No.	Measuring Range mm / Inch	L.C.
1.	0-150 / 6"	0.01mm
2.	0-200 / 8"	0.01mm
3.	0-300 / 12"	0.01mm

DOUBLE HOOK DIGITAL CALLIPER



Sl. No.	Measuring Range mm	L.C.
1.	200	0.01mm
2.	300	0.01mm

CARBON FIBRE DIGITAL CALLIPER



Sl. No.	Measuring Range mm	L.C.
1.	150	0.01mm

SOLAR DIGITAL CALLIPER



Sl. No.	Measuring Range mm	L.C.
1.	150	0.01mm

HIGH ACCURACY DIGITAL CALLIPER



Sl. No.	Measuring Range mm	L.C.
1.	150	0.005mm

INSIDE GROOVE DIGITAL CALIPERS



Sl.No.	Measuring Range mm / Inch	L.C.
1.	24-150	0.01mm
2.	30-300	0.01mm

OUTSIDE GROOVE DIGITAL CALIPERS



Sl.No.	Measuring Range mm / Inch	L.C.
1.	0-150 / 6"	0.01mm
2.	0-300 / 12"	0.01mm

OFFSET DIGITAL CALIPERS



Sl.No.	Measuring Range mm / Inch	L.C.
1.	0-150 / 6"	0.01mm
2.	0-200 / 8"	0.01mm
3.	0-300 / 12"	0.01mm

SETTING CALLIPER



Sl. No.	Measuring Range mm	L.C.
1.	150	0.05mm
2.	200	0.05mm
3.	300	0.05mm

DIGITAL SETTING CALLIPER



Sl. No.	Measuring Range mm	L.C.
1.	150	0.01mm
2.	200	0.01mm
3.	300	0.01mm

RTJ GROOVE DIGITAL CALLIPER



Sl. No.	Measuring Range mm	L.C.
1.	300	0.01mm
2.	600	0.01mm

KNIFE EDGE DIGITAL CALLIPER



Sl. No.	Measuring Range mm	L.C.
1.	200	0.01mm
2.	300	0.01mm

CENTER TO CENTER CALLIPER.PNG



Sl. No.	Measuring Range mm	L.C.
1.	300	0.01mm

BALL CALLIPER



Sl. No.	Measuring Range mm	L.C.
1.	150	0.01mm

INTERCHANGEABLE DIGITAL CALLIPER



Sl. No.	Measuring Range mm	L.C.
1.	300	0.01mm

DIGITAL GEAR TOOTH CALIPERS

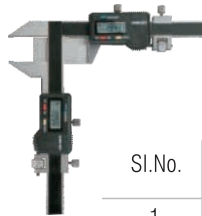

Sl.No.	Measuring Range mm	L.C.
1.	m1-25	0.01mm
2.	m5-50	0.01mm

DIGITAL BRAKE DRUM CALLIPER



Sl. No.	Measuring Range mm	L.C.
1.	300mm	0.01mm
2.	500mm	0.01mm

ADJUSTABLE OUTSIDE MICROMETERS



Sl.No.	Measuring Range	L.C.
1.	0-100mm	0.01mm
2.	0-150mm	0.01mm
3.	50-150mm	0.01mm
4.	100-200mm	0.01mm
5.	150-300mm	0.01mm

ADJUSTABLE OUTSIDE MICROMETERS

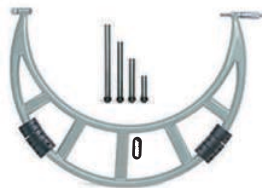

Sl.No.	Measuring Range mm	L.C.
1.	300-400	0.01mm
2.	400-500	0.01mm
3.	500-600	0.01mm
4.	600-700	0.01mm
5.	700-800	0.01mm
6.	800-900	0.01mm
7.	900-1000	0.01mm
8.	1000-1200	0.01mm
9.	1200-1400	0.01mm
10.	1400-1600	0.01mm

OUTSIDE MICROMETERS



Sl.No.	Measuring Range mm	L.C.
1.	0- 25mm	0.01mm
2.	25-50mm	0.01mm
3.	50-75mm	0.01mm
4.	75-100mm	0.01mm
5.	100-125mm	0.01mm
6.	125-150mm	0.01mm
7.	150-175mm	0.01mm
8.	175-200mm	0.01mm
9.	200-225mm	0.01mm
10.	225-250mm	0.01mm
11.	250-275mm	0.01mm
12.	275-300mm	0.01mm

OUTSIDE DIGITAL MICROMETERS



Sl.No.	Measuring Range mm	L.C.
1.	0-25	0.01mm
2.	25-50	0.01mm
3.	50-75	0.01mm
4.	75-100	0.01mm

*(Water Proof IP54 also available)

DIGITAL SNAP MICROMETER



Sl. No.	Measuring Range mm	L.C
1.	0-25	0.001mm
2.	25-50	0.001mm
3.	50-75	0.001mm
4.	75-100	0.001mm

DEPTH MICROMETER



Sl. No.	Measuring Range mm	L.C.
1.	0-25	0.01mm
2.	0-50	0.01mm
3.	0-100	0.01mm
4.	0-150	0.01mm
5.	0-300	0.01mm

SCREW THREAD MICROMETERS



Sl.No.	Measuring Range mm / Inch	L.C.
1.	0-25mm	0.01mm

ELECTRONIC MICROMETER

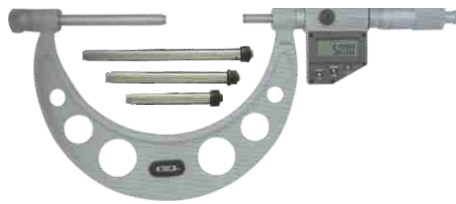

Sl. No.	Measuring Range mm	L.C
1.	0-150	0.001mm
2.	150-300	0.001mm
3.	300-400	0.001mm
4.	400-500	0.001mm

INSIDE MICROMETERS



Sl.No.	Measuring Range mm	L.C.
1.	5-30mm	0.01mm
2.	25-50mm	0.01mm

TUBULAR INSIDE MICROMETERS



Sl.No.	Measuring Range mm	L.C.
1.	50-150	0.01mm
2.	50-300	0.01mm
3.	50-500	0.01mm
4.	50-1000	0.01mm

THREE-POINT INTERNAL MICROMETERS



Sl.No.	Measuring Range mm	L.C.
1.	6-12	0.001mm
2.	12-20	0.005mm
3.	20-50	0.005mm
4.	50-100	0.005mm

ELECTRONIC THREE POINT INTERNAL MICROMETER



Sl. No.	Measuring Range mm	L.C
1.	6-12	0.001mm
2.	12-20	0.001mm
3.	20-50	0.001mm
4.	50-100	0.001mm

DISC MICROMETER

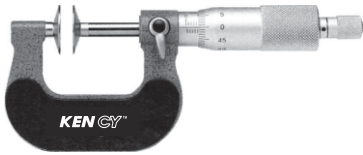

Sl. No.	Measuring Range mm	L.C.
1.	0-25	0.01mm
2.	25-50	0.01mm
3.	50-75	0.01mm
4.	75-100	0.01mm

BLADE MICROMETER



Sl. No.	Measuring Range mm	L.C.
1.	0-25	0.01mm
2.	25-50	0.01mm
3.	50-75	0.01mm
4.	75-100	0.01mm

TUBE MICROMETER



Sl. No.	Measuring Range mm	L.C.
1.	0-25	0.01mm
2.	25-50	0.01mm

DIGITAL TUBE MICROMETER



Sl. No.	Measuring Range mm	L.C.
1.	0-25	0.001mm
2.	25-50	0.001mm

DIGITAL DISC MICROMETER



Sl. No.	Measuring Range mm	L.C.
1.	0-25	0.001mm

DIGIMATIC BLADE MICROMETER



Sl. No.	Measuring Range mm	L.C.
1.	0-25	0.001mm
2.	25-50	0.001mm

HUB MICROMETER



Sl. No.	Measuring Range mm	L.C.
1.	0-25	0.01mm

CAN SEAM MICROMETER



Sl. No.	Measuring Range mm	L.C.
1.	0-25	0.01mm

GROOVE MICROMETER



Sl. No.	Measuring Range mm	L.C.
1.	0-25	0.01mm

LIMIT MICROMETER



Sl. No.	Measuring Range mm	L.C.
1.	0-25	0.01mm

DIGITAL DEPTH MICROMETER



Sl. No.	Measuring Range mm	L.C.
1.	0-25	0.001mm
2.	0-150	0.001mm

DIAL MICROMETER



Sl. No.	Measuring Range mm	L.C.
1.	0-25	0.01mm

QUICK MINI



Sl. No.	Measuring Range mm	L.C.
1.	0-12	0.01mm
2.	0-25	0.01mm

DIGITAL TIRE DEPTH GAUGE



Sl. No.	Measuring Range mm	L.C.
1.	0-25	0.01mm

MINI THICKNESS GAUGE



Sl. No.	Measuring Range mm	L.C.
1.	12	0.001mm

THICKNESS GAGE



Sl. No.	Measuring Range mm	L.C.
1.	0-10	0.1mm
2.	0-20	0.1mm

DIGITAL INDICATORS



Sl.No.	Measuring Range mm / Inch	L.C.
1.	0-10	0.01mm
2.	0-10	0.001mm

DIGITAL THICKNESS GAGES



Sl.No.	Measuring Range mm / Inch	L.C.
1.	0-10	0.01mm
2.	0-10	0.001mm

DIAL THICKNESS GAUGE



Sl. No.	Measuring Range mm	L.C.
1.	0-10	0.01mm
2.	0.10	0.001mm

DIAL GAUGES



Sl.No.	Measuring Range mm / Inch	L.C.
1.	0-10	0.01mm
2.	0-1	0.001mm

LEVER DIAL



Sl.No.	Measuring Range mm / Inch	L.C.
1.	0.8	0.01mm
2.	0.2	0.002mm

DIGITAL LEVER DIAL



Sl. No.	Measuring Range mm	L.C.
1.	0-0.8	0.01mm

GAUGE BLOCK SET



Block Per Set
32,83 & 112 Pieces
Grade 2 & Grade 0

INSIDE DIGIMATIC CALLIPER



Sl.No.	Measuring Range mm	L.C.
1	5-25	0.005mm
2	10-30	0.005mm
3	20-40	0.005mm
4	30-50	0.005mm
5	40-60	0.005mm

INSIDE DIAL CALIPERS



Sl.No.	Measuring Range mm	L.C.
1	5-25	0.01mm
2	10-30	0.01mm
3	20-40	0.01mm
4	30-50	0.01mm
5	40-60	0.01mm

BORE DIAL GAUGES



Sl.No.	Measuring Range mm	L.C.
1.	10-18	0.01mm
2.	18-35	0.01mm
3.	35-60	0.01mm
4.	50-150	0.01mm
5.	160-250	0.01mm
6.	250-450	0.01mm
7.	400-600	0.01mm
8.	600-800	0.01mm

DIGITAL HEIGHT GAGES



Sl.No.	Measuring Range mm / Inch	L.C.
1.	0-300 / 12"	0.01mm
2.	0-600 / 24"	0.01mm

DIGITAL SHORE HARDNESS TESTER

Specifications

Display : 3 Digits 10mm LCD
 Range : 0-100mm
 Resolution : 0.1mm
 Weight : 170gm



PK 1000 SA

HEIGHT GAGES



Sl.No.	Measuring Range mm	L.C.
1.	0-300	0.02mm
2.	0-600	0.02mm
3.	0-1000	0.02mm

ANGLE FINDER



Specifications

Accuracy	: +/- 5°
Material	: Stainless Steel Throughout
The Blade	: 150, 300mm
Contact Force	: 1.5N or Less
Work Temperature	: +5°C ~ +50°C
Power	: 3V Cr2032 Lithium Battery

BEVEL BOX - LEVEL



Specifications

Resolution	: 0.1°
Repeatability	: 0.1°
Measuring range	: ±180° (0~360°)
Working current	: <100mA
Work temperature	: +5° C~+50° C
Work humidity	: <85%RH
Power	: 3V Cr2032 Lithium battery

DIGITAL PROTRACTOR - LEVEL



Specifications

Resolution	: 0.1°
Accuracy	: 0° and 90° <0.1° ; the rest <0.2°
Measuring range	: 4 x 90° (0~360°)
Working current	: <100mA
Work temperature	: +5° C~+50° C
Work humidity	: <85%RH
Power	: 3V Cr2032 Lithium battery

UNIVERSAL PROTRACTOR



Specifications

Accuracy	: +/-5'
Material	: Stainless Steel throughout
The blade	: 150mm, 300mm
Contact force	: 1.5N or less
Work temperature	: +5°C~+5°C
Power	: 3V Cr2032 Lithium battery

COATING THICKNESS GAUGE



PK 1000 F



PK 1000 FN

Specifications

Display	: 4 Digits 10mm LCD
Range	: 0~1250um / 0~50mil (selectable)
Resolution	: 0.1um or 0.5mil
Accuracy	: ±1~3% or +/-2.5%um
Min. Measuring Area	: 6mm
Min. Radius of Curvature	: Fe: Convex 1.5mm / Concave 25mm Nin Fe : Convex 3mm Concave 50mm
Power Source	: 4 x 1.5V AAA (Um4) battery
Weight	: Main Unit 85grams (without battery)
Standard Accessories	: Processor unit "0" Calibration base. Calibration FOIL 4
Packing	: Tough ABS plastic carrying case
Optional	: RS232C software, interface cable

DIGITAL ULTRASONIC THICKNESS GAUGE

Specifications

Display	: 4 Digits 10mm LCD
Range	: 1.0 - 200mm
Resolution	: 0.1mm / 0.001 inch
Accuracy	: +/- (0.5%n + 0.1)
Sound Velocity	: 500-9000 m/s
Power Supply	: 4x1.5V AAA (UM-4) Alkaline cells
Operating Temperature	: 0.50 Humidity < 80%
Dimensions	: 120 x 62 x 30mm (4.7 x 2.4 x 1.2 inch)
Weight	: 164gms (without batteries)
Standard Accessories	: Carrying case: 1pc., Operation manual: 1 pc.,
Processor unit: 1 pc., Senspr probe: 1 pc.	
Optional Accessories	: Cable & software for RS232C



PK 1000 UT

DIGITAL BELT TENSION TESTER

The Digital Belt Tension Tester is used to measure and adjust the tension of Timing and Auxillary Belts fitted on Motor Vehicles and other Machines.

Why Belt tensioning required?

A Properly tensioned Belt ensures smooth operation and extends the service life of motor and machines. Conversely an improperly tension Belt can cause a host of easily preventable problems, including noise, vibration, poor performance, bearing wear, shortened motor life and high power bills.

How to Measure?

The measuring head is placed on the belt and the clamp is tightened using the clamping knob. This deflects the belt through a known angle defined by the anvil and fixed Pillars. The output voltage from the load cell is digitalized and sealed to give correct tension reading.

Specifications

Measurement Range	: 0-750 Newtons, 0-120 Pounds, 0-77 Kilograms, 0-114 Seems
Belt Width	: Up to 36mm
Overload Alarm	: 750 Newtons
Maximum Load	: 850 Newtons
Resolution	: ± 1 Newtons or 1 least significant digit of other units
Accuracy	: $\pm 5\%$ of full scale
Operating Temperature	: 0° - 40° C
Accessories	: Measuring Head - 1Pc Carrying Case - 1Pc Operation Manual - 1Pc



GLOSS METER



A Gloss meter is an Instrument which is used to measure Specular Reflection Gloss of a surface.

Principle of Measurement?

Gloss is determined by projecting a beam of light at a fixed intensity and angle, onto a surface and measuring the amount of reflected light at an equal but opposite angle.

Application

Many Industries use Gloss Meter in their quality control department to ensure consistency in their manufacturing Process.

The Automobile Industry is a major user of the gloss meter with applications extending from the factory floor to the repair shop.

Specifications

Measuring geometry	
Angle	: 20° , 60° & 85°
Range	: 0.1 to 20 gloss units
Accuracy	: ± 1.0 gloss unit
Resolution	: 0.1 gloss unit
Operating Temperature	: 0° - 40° C
Power Supply	: Lithium Battery
Accessories	: Operation Manual, Power Adaptor Holder with Calibration Standard.

ULTRASONIC THICKNESS GAUGE

An Ultrasonic Thickness Gauge is a measuring Instrument used for non destructive measurement of thickness using Ultrasonic Waves.

Principle of Measurement?

A rugged Ultrasonic Thickness Gauge determines sample thickness by measuring the amount of time it takes sound to tranverse from the transducer through the material to the back end of a part an then measures the time which the reflection takes to get back to the transducer. The Ultrasonic Gauge then calculates the size based on the speed of the waves through the tested sample.

What Materials it can be used on?

It Measures thickness of Steel, Aluminium Copper, Glass, Plastic, Zinc

Specifications

Measurement range	: 1.2mm-220mm (steel)
Tubes measurement	: Minimum $\square 20\text{mm} \times 3\text{mm}$
Ultrasonic wave velocity	: 1000-9999 M/S.
Resolution	: 0.1mm.
Accuracy	: $\pm (1\%H + 0.1\text{mm})$
Operating temperature	: -10- +50 °C..
Accessories	: Probs, coupling paste, operating manual, batteries.
Unit of Measurement	: inch & mm Optional.



DIGITAL COATING THICKNESS GAUGE



Principle

The Coating Thickness Gauge easily measures all coatings on metallic substrates using the Magnetic Induction or Eddy Current principles.

Application

It is used for measuring Non-Ferromagnetic metal coatings eg. Chrome, Copper, Zinc, Paint on Ferromagnetic material i.e Steel and Iron. Highly used in Paint & Electroplating Industry and also extensively in the Automobile Industry.

Specifications

Measurement range	: 0-1250 $\square\text{m}$.
Resolution	: 1 $\square\text{m}$.
Accuracy	: $\pm (3\%H + 2\text{m})$.
Display units	: $\square\text{m}$ or mil
Minimum thickness of metallic base	: 0.2mm.
Minimum curvature radius	: protruding 1.5mm, concave 6mm.
Probe diameter	: 13mm.
Operating environment	
Temperature	: 0-50°C
Humidity	: 20%-80%
Accessories	: probe, standard thickness pieces(5), matensite stainless steel block, operating manual, batteries.

LEEB HARDNESS TESTER

FEATURES AND SPECIFICATIONS

Applications

- * Die cavity of molds
- * Inspection of bearing and other mass produced parts on a production line
- * Failure analysis of pressure vessel, steam generator and other equipment
- * Inspection of installed machinery, permanent parts of assembled systems and heavy work pieces.
- * Testing surface of a small hollow space
- * Material identification in the warehouse of metallic materials
- * Rapid testing in large range and multi-measuring areas for large-scale work piece

Testing Features

- * Palm size for narrow space.
- * Test at any angle, even upside down.
- * Direct display of hardness scales HRB, HRC, HV, HB, HS, HL.
- * Large memory could store 50 groups including single measured value, impact direction, material and hardness scale etc.
- * User recalibration function allowed.
- * Can communicate with PC computer for statistics and printing by the optional cable.
- * Manual or automatic shut down.
- * Low battery indication.

Technical Specifications

Display : LCD with back light
 Accuracy: Display error $\pm 0.8\%$ at LD= 900
 Measuring range: 170-960 HLD
 Conversion: HL -HRC -HRB -HB -HV -HSD
 Materials: 9 different common materials
 Memory: 50 data can be stored and re-readable
 Impact device: D Will handle the majority of hardness testing applications. Weight: 75g
 Power supply: 2x1.5V AA (um-3) size battery
 Dimension: 130x76x32mm
 Weight: 340g (not including batteries)
 Working temperature : 0~40°C
 Storage temperature : -30~60°C
 Relative humidity: $\leq 90\%$



CALIBRATION

After a long period of use, especially for measuring harder materials, the ball tip of impact body will be worn which may lead the tester have more or less error on accuracy. At this moment, this tester is designed to allow recalibration. The calibration can be made in the following way. pressing **POWER/MENU** key for 8 seconds into item CAL, and the tester now is in the calibration mode. Take measurements on the standard test block. Use **RD/▲** key or **DEL/▼** key to adjust the reading on the display to the standard value. Press **POWER/MENU** key to quit from the calibration mode and return to the measurement mode. Please note: If the measurement error comes within the range of accuracy specification, please do not make calibration easily.

Measuring and Converting Ranges

Material	HL	HRC	HRB	HB		HS	HV
				30D ²	10D ²		
Steel & Cast St.	300~900	20.0~68.0	38.4~99.5	80~647		32.5~99.5	80~940
C.W. Tool Steel	300~840	20.4~67.1					80~898
ST. STEEL	300~800	19.6~62.4	46.5~101.7	85~655			80~802
Gray Cast Iron	360~650			93~334			
Nodular Cast Iron	400~660			131~387			
Cast Aluminum	174~560				20~159		
Brass	200~550		13.5~95.3		40~173		
Bronze	300~700				60~290		
Copper	200~690				45~315		



KENCY™

Maap
INSTRUMENTATION

Register Off: 264, Dr. Nanjappa Road,
Coimbatore - 641 018, Tamil Nadu, India.
Tel: 0422 - 3238768, 4072250 Mob: 94425 22350
Fax: 0422 - 2231002
E-mail: maapinstrumentation@hotmail.com
Web: www.maap.net.in

service & calibration



orient

EQUIPMENT & SERVICES

orientequipmentservices.com



Sales | Service | Calibration

Introduction

Orient Equipment & Services (OES) was established as a service arm of Orient Hardware & Tools Corporation (Orimart) a 60 years old Industrial house of engineering tools and equipments. The facility was started in 1992 for servicing portable power tools in a 400 Sq ft workshop with a single technician. Today it has grown to a 2000 sq ft of Tools & hardware showroom and also 5000 sq ft of workshop area. We have 45 skilled professional team for sales & service. In our workshop, We have individual departments, specially for electric Tools, Pneumatic Tools, Measuring Instruments, Hydraulic Equipments, Machinery, Electrical & Electronics, etc.

Philosophy

We were the first in the country to have an infrastructure to provide professional service to the industry and give extended life to tools and equipments which were prematurely discarded. We would continue to lead the service industry with innovation and knowledge. We employ skilled and trained manpower using the latest technology in the industry to reduce the down time and ensure longevity of every engineering product used.



Strength

The 45 members strong motivated team are our strength. Their contribution in the field of sales, service and calibration has helped us to achieve sustained growth and also demand a commendable faith and goodwill with our customers. We will continue to train and motivate them in the process of giving you world class service. We do have a strong sub dealer network, which enhance our sales strength.

Our Customers

We thank our 1500 plus dedicated customers who found faith in us. Our customers range from Aero Space, Transport Organizations, Sugar Mills, Automobile industries, Foundries, Cement Factories, Engineering Industries, Wind Mill Manufacturers and Service Providers, Textile Mills, Educational Institutions, Hospitals, etc. The list is rapidly growing and so is our strong commitment to them.

Thank you Dear Customers !!!!!!!!



we calibrate ...



Certificate No
CC - 2154

NABL Accredited Lab

Length Measuring Instruments



Vernier Caliper, Vernier Height Gauge,
Micrometer, Plunger Dial, Lever Dial,
Bore Gauge, Groove Dial Caliper,
Dial Thickness Gauge, Pistol Caliper.

Pressure Gauges



Vaccum Gauge,
Industrial Pressure Gauge,
Digital Pressure Indicator,
Digital Pressure Transmitter.

Electrical Instruments



Multi Meter, Clamp Meter
Ammeter/Volt Meter, Frequency Meter,
KV Tester, Insulation Tester,
Sound Level Meter.

Gauge



Feeler Gauge, Plain Plug Gauge,
Coating Thickness Gauge, Snap Gauge,
Width Gauge, Pin Gauge, Plain Ring Gauge,
Thread Plug Gauge, Slip Gauge.

Torque Wrenches



Torque Multiplier, Torque Wrench

Weighing Balance



Weighing Balance & Scale.

Spirit Level



Horizontal & Vertical Sprit Level

Thermal



Temperature Sensor,
Oven Thermocouple,
Temperature Transmitter,
Temperature Recorder,
Temperature Indicator,
Temperature Controller

Surface Table



Engineer Square,
V Block,

Profile Projector



Bevel Protector, Pitch Gauge,
Radius Gauge, Measuring Tape,
Steel Scale, Test Sleeve

Orient Equipment & Services offers a world class calibration centre in Coimbatore for Calibrating high precision instruments. We meet the requirements of IS/ISO/IEC 17025:2005 Standards with a team of highly skilled professionals. The Calibration Centre caters to Parameters like Pressure, Torque, Electro Technical, Thermal and Precision Linear Measurements.

We just don't calibrate "we service too"

we retail ...

Power Tools & Pneumatic Tools



Welding Equipments & Accessories



Hand Tools



Garage Equipments



Material Handling Equipments



Personal Protective Equipments



we retail ...

Thread Inserts, Toggle Clamps & Fasteners



Measuring Instruments



Abrasives



Cutting Tools



Machineries



Garden Tools & Equipments



we service ...

Power Tools



Pneumatic Tools



Electrical Instruments



Measuring Instruments



Gas Equipments



Spirit Level



Torque Wrenches



Hydraulic Equipments



Garage Equipments



Textile Instruments



Material Handling Equipments



Machine Tools



Gardening Equipments



Cordless Tools



Welding Machines



Office Automation Products



Spray Guns



Electronic Instruments



we specialize ...

High-Frequency Technology

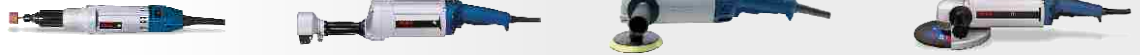
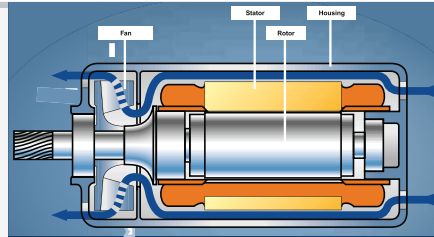

Robust technology for heavy-duty continuous use
A high-frequency motor is a three-phase current motor with a short-circuit rotor. Its stator and its rotor consist of a laminated sheet-metal bundle. If the stator winding of the motor is connected to the three phase current supply, a magnetic field is created (rotary field), which runs through the motor due to the arrangement of the winding and which is dependent on the number of pole pairs and the frequency.

Angle Shut-off Wrenches with Shut-off Clutch



Shut-off clutch for very fine torque setting and minimal torque dispersion
Long lifetime
External torque setting
Small, rotating angle head
Exhaust air hose optional
Low-noise

Impulse Drivers



Clean technology
Extremely lightweight impulse driver.
Wear-free shut-off clutch that reacts to mechanical centrifugal force.
Impulse unit with innovative, unique piston compression principle consisting of only three parts with seals. This means less oil consumption, rapid oil change and optimised integrated cooling.
High speed due to robust, powerful motor with dual chamber for fast, efficient working.
Right-hand/left-hand rotation.
Greater torque in left-hand rotation, in order to loosen screws more easily.

Exact Tools



Higher efficiency was the key development target for the new series of Bosch EXACT Cordless Screwdrivers with the SEC motor. This sensor less and brushless motor technology sets the bench mark in terms of low energy consumption, lowest weight and highest power (torque and speed).

Authorised Sales & Service



We also Cater to :

Construction Industry | Educational Institutions | Hotels | Medical | Plantations | Agriculture

Comprehensive Power Tool Solutions

orient
EQUIPMENT & SERVICES

**HEAD OFFICE : 295, Dr, Nanjappa Road, Coimbatore - 641 018
T : 0422 - 223 0286, 223 8507, M : 88833 65222, 75982 17970
E : sales1@orientequipment.co.in**

**BRANCH : 45, Grey Town, Coimbatore - 641 018
T : 0422 - 230 6655, M : 99769 65222
E : sales2@orientequipment.co.in**

**SERVICE & CALIBRATION : 97, Sastri Road, Ramnagar, Coimbatore - 641 009
T : 0422 - 223 6432, 421 8600, M : 99428 65222
E : service@orientequipment.co.in**

**Sales :
75982 17970**

**Branch :
99769 65222**

**Service :
99428 65222**

**Calibration :
75982 06432**

skill development

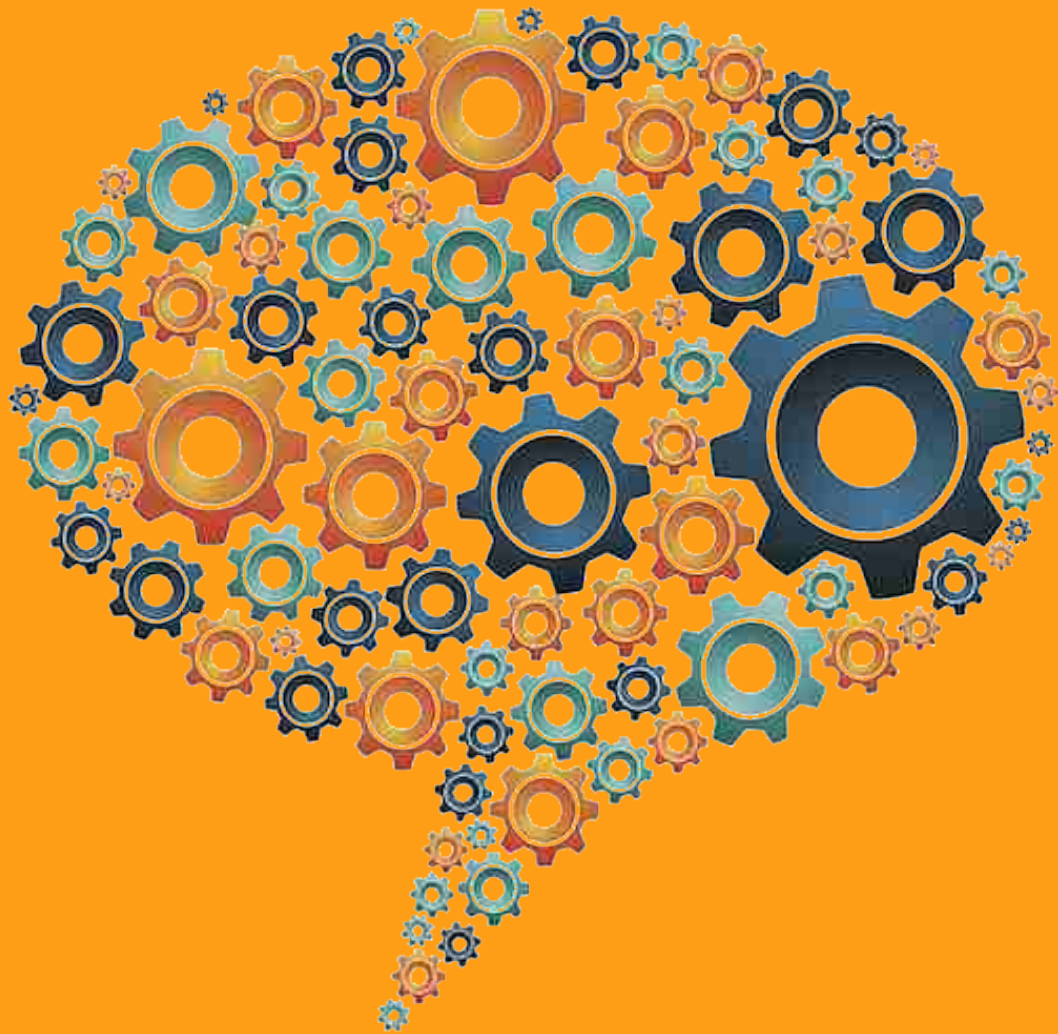



Gedee - WIM

INSTITUTE OF WELDING TECHNOLOGY

(A Unit of G D Naidu Charities)

APPROVED BY THE INDIAN INSTITUTE OF WELDING (IIW)
COIMBATORE

... imparting 100 years of acquired knowledge



Registration Open

www.gedeewim.in

pursuing the footsteps of the legacy of the founder



"To learn for 25 years, though not in school alone.
To earn for 25 years, To spend what I have learnt
and earned after these 50 years for the welfare of others."

- Shri G D Naidu

In today's scenario, it has become difficult to recruit and employ skilled manpower.

This is now a step closer

G D Naidu Charities (GDNC), Coimbatore, India in association with **Welding Industries Malaysia Sdn. Bhd., Malaysia (WIM)** has established a state of the art, Welders Training Institute, set to global standards.

ABOUT US:

Gedee : Late Shri G.D.Naidu, was a successful industrialist, a keen educationalist, philanthropist and a great innovator of South India. In 1946, he started an institute in the name of Industrial Labour Welfare Association (ILWA), now known as G.D.Naidu Charities. His aim was to impart higher education with more emphasis on practical training so that students can get employment immediately.

Gedee Technical Training Institute (GTI), unit of G.D Naidu Charities, in association with IHKNuremberg, Germany, has been conducting courses on Precision Machining Technology, Tool and Die Engineering, Mechatronics and advanced course in Tool design and Mechatronics. Other than this G.D. Naidu charities is conducting short term courses on Automobile Service and Maintenance in association with Volkswagen, Pune, and various other short term courses such as EDM, CMM, CAD(Autocad, Pro-E, Inventor, Power Shape, CATIA, ANSYS, SOLID WORKS, etc), CAM(Keller, Delcam, Unigraphics), Metrology, CMM, etc. it has trained more than 50,000 Students over the past 6 decades.

WIM : Welding Industries Malaysia (WIM) founded in 1972, is an international manufacturer and global supplier of World Class Welding and Cutting equipments. As a leader and prime manufacturer in the industries of welding products, it has an on-going commitment to produce high quality welding products and offer services. WIM won the Best Product Award 2003 given by SMI Malaysia. About 70 per cent of the components in the welding machines, particularly key parts like transformers and PCB are made in house by WIM.

WIM is proud to be at the fore front of welding industry, a position which will be reinforced by new product planning and innovative strategies. Global Marketing represents a substantial proportion of WIM's business. WIM products are present across the globe in over 45 countries. WIM in India at present is a joint venture and is more than 12 years old. Our commitment to the society and its requirements has led us to undertake this mission of providing quality welding training. WIM is the official Welding Training provider for the GIATMARA Scheme of Government of Malaysia.



Our Mission

"To enhance the skill set of a person, enable them to perform at the best in their jobs and career thereby contribute to the overall growth of the industry"

Our Motto

TOTAL WELDING SOLUTIONS

OUR QUALITY OBJECTIVES

- Prepare the trainee for industrial adaptability and soft skills.
- Train to fabricate and manufacture products by which the trainee learns all aspects of designing, drawing and fabrication.
- "LEARNING BY DOING" with stress on 70% practicals.
- Update the training syllabus regularly & provide the state of the art technologies for training.
- Interact with the industries to impart knowledge to suit their requirements.

WHY GEDEE WIM ?

- Over 100years of association with the fabrication Industries.
- State of the art infrastructure.
- Internationally trained instructors.
- 70% allocation of course duration for practical's.
- Special focus on other welding and fabrication related activities.
- Internationally recognized curriculum.
- Internationally approved certification.
- Placement opportunities in over 40 countries through established networks.





Process



OXY ACETYLENE CUTTING & WELDING



ARC



MIG



TIG



PLASMA



SPOT



SUBMERGED ARC



DIESEL ENGINE DRIVE



MULTI PROCESS



MULTI - OPERATOR



AUTOMATION



LASER

Infrastructure

- 1 5000 Sq. Ft. Of Institute Area
- 2 20 Dedicated Welding Booths
- 3 Separate Store for Consumables
- 4 Separate Store for Equipments
- 5 Separate Location for Trainees Personal Protective Equipments
- 6 Separate Location to Store Gas Cylinders
- 7 Adequate Power to Operate Welding and Cutting Equipments
- 8 Dedicated Computer Lab
- 9 Class Room with Computer and Projector to Accommodate 30 Trainees



Courses Offered

Sl.No.	Course Code	Name of the Course	Duration
1	GWI - 01 - G	Familiarisation of Gas Welding	1 Week
2	GWI - 01 - S	Familiarisation of ARC / SMAW	1 Week
3	GWI - 01 - M	Familiarisation of MIG / GMAW	1 Week
4	GWI - 01 - T	Familiarisation of TIG / GTAW	1 Week
5	GWI - 02 - G	Basic on Gas Welding	3 Weeks
6	GWI - 02 - S	Basic on ARC / SMAW	3 Weeks
7	GWI - 02 - M	Basic on MIG / GMAW	3 Weeks
8	GWI - 02 - T	Basic on TIG / GTAW	3 Weeks
9	GWI - 03 - S	Basic on ARC / SMAW	8 Weeks
10	GWI - 03 - M	Basic on MIG / GMAW	8 Weeks
11	GWI - 03 - T	Basic on TIG / GTAW	8 Weeks
12	GWI - 04 - S	Standard or Regular - ARC / SMAW	8 Weeks
13	GWI - 04 - M	Standard or Regular - MIG / GMAW	8 Weeks
14	GWI - 04 - T	Standard or Regular - TIG / GTAW	8 Weeks
15	GWI - 05 - P	Special Course on Pipe Welding	2 Weeks
16	GWI - 06 - C	6 Months Certificate Course in Welding Technology	24 Weeks
17	GWI - 07 - D	1 Year - Diploma Course in Welding Technology	48 Weeks
18	GWI - 08 - PD	2 Years - Post Diploma Course in Welding Technology	96 Weeks
19	GWI - 10	Customised Program	

Location Map

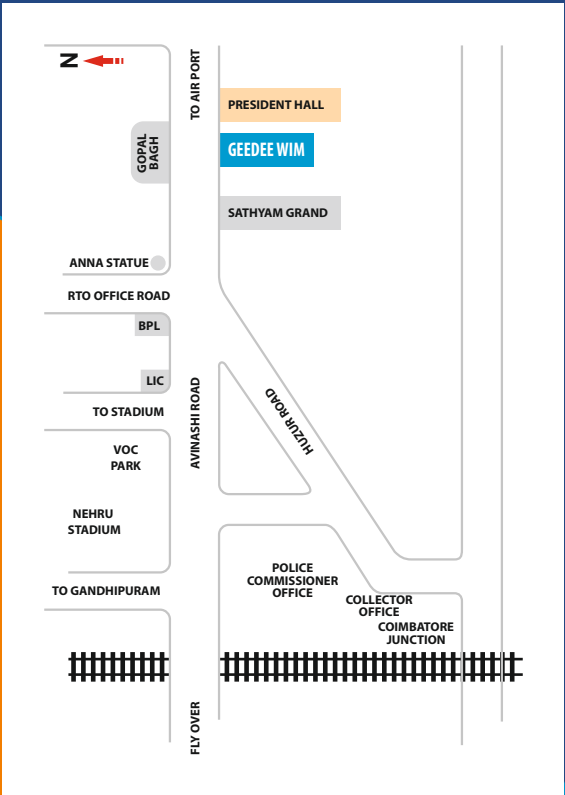

G D NAIDU CHARITIES
initiative in Technical Association with
WELDING INDUSTRIES MALAYSIA SDN. BHD



GEDEE WIM INSTITUTE OF WELDING TECHNOLOGY
APPROVED BY THE INDIAN INSTITUTE OF WELDING (IIW)
734, Avinashi Road, COIMBATORE 641 018, TAMIL NADU, INDIA
Tel : +91 422 2222243, Mobile : +91 94438 43261, Fax : +91 422 2242760
Email: gedeewim@gmail.com; www.gedeewim.in

welder
&
automobile bodyshop
technician training



OBS

Your **ALL IN ONE**
Body Shop Solution

About Us

Orient Bodyshop Solutions or commonly known as OBSS was incorporated in the year 2011. The core idea of the company was to offer customers specialized product and services in the area of Body and Paint. Situated in Coimbatore, OBSS has a manufacturing setup, with machineries for sheet metal and heavy fabrication. Currently manufacturing World class inverter spray booth, Crash repair system, Tyre Inflation Equipment, Spray gun cleaning equipment, special tools and many more. OBSS are the distributors for some of the world's leading equipment brands like CELETTE, GYS, IRT, TKR, HESHBON etc. These products are imported and stocked for an on-time delivery to customer needs.



















At OBSS, Training is the core strength and this is reflected in the investment made at the Training centre located inside OBSS facility. OBSS offers training courses on Body and Paint process as well as on the equipment. The training courses are recognized and used by some of the leading vehicle manufacturers. OBSS has a dedicated technical team which is working towards Engineering and R&D on equipment. Some of the product delivered by this team are Inverter based Spray Booth with VARIO-D technology, Crash repair system with quick clamping mechanism, indigenized spray gun cleaner for water borne paints, Retrofit for Paint booth to handle water borne paints, Specialized Trolley for quick repair and vehicle movement, Nitrogen Tyre Inflator and many more.

The complete range of products manufactured and distributed products are backed by a wide sales network.

With the current strength on Training, Marketing, customer support, Engineering and production OBSS is looking towards a leadership position in the Indian Workshop Equipment Industry.



Product Recommended and Used by :

 RENAULT	 NISSAN		 CITROËN	
	 VOLVO	LAND ROVER	JAGUAR	MERCEDES
EvoBus				VOLKSWAGEN GROUP
		TESLA	Jeep	 Mahindra
 TATA		 EICHER		



- | Quick-Anch technology
- | Drive-on and Ready to pull within 5 mins
- | Robust design
- | Lifting capacity – 3 Ton / Premium 4 Ton
- | Pulling Capacity – 10 Ton
- | Premium range of Pulling accessories
- | Ideal for Minor, Medium and Major damage repair

“Vehicle is ready to pull within 5 min”

1

Drive the vehicle on the bench



2

Slide the sill clamp



3

Fasten the sill clamp and raise the bench



Chassis clamping attachment



Complete range of pulling accessories



Crash Repair System - Celette Sevenne with Dedicated JIGS



- | Provides at least 30 Anchor and Control points to ensure absolute accuracy.
- | Provides not only X, Y, and Z dimensions, but also the angle of inclination of each unique point.
- | Provides a quick and perfect vehicle template, allowing for a precise repair that is comparable to the quality achieved during the production process of new vehicles.
- | Firmly anchors previously repaired points during pulling
- | Especially suited to the repair of vehicles constructed from modern materials, e.g. aluminium, composite carbon fibre, and high strength steel.
- | Sevenne XL is the only bench approved by all motor manufacturers, and it's mobile nature implies that it can return it's investment both in and outside the aluminium workstation.

Crash Repair System – Celette Rhone

- | Pulling capacity – 10 Ton
- | Lifting capacity (Scissor) – 2.8 Ton
- | Pulling capacity – 10 Ton
- | Complete drive-on platform



Electronic Measuring System – Celette Naja

- | User friendly software for easy use
- | High accuracy and reliability
- | No risk of faulty readings with green (for good) and red (for faulty) symbols
- | Bluetooth wireless communication between the computer and the sliding head
- | Readings can be recorded and printed for full traceability

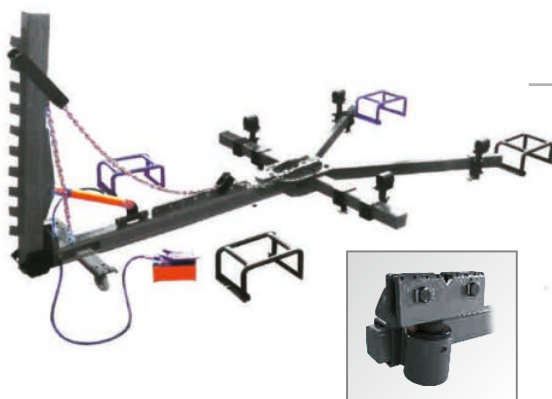

Crash Repair System – OBSS MINI 10

- | Simple design
- | Economical system
- | Quick clamping
- | Ideal solution for Minor and Medium damage repair

GYS - Steel Dent Puller



GYSPOT 39.02

- | Portable dent pulling equipment
- | Ideal for small and medium repairs
- | Welding current – 3800 amps
- | Synergic controlled
- | Automatic torch



EASYLINER 39.02

- | Complete dent pulling kit
- | Ideal for repairing small, medium repairs
- | Welding current – 3800 amps
- | Synergic controlled
- | Automatic torch



SPEEDLINER 39.02

- | Complete dent pulling station
- | Ideal for repairing small, medium and big repairs
- | Welding current – 3800 amps
- | Synergic controlled
- | Automatic torch

Aluminium Dent Puller



GYSPOT ALU GYSDUCTION

- | Portable dent pulling equipment
- | Ideal for small and medium repairs
- | Welding current – 7500 amps
- | Synergic controlled
- | Automatic torch
- | Capacitor discharged



PROLINER ALU

- | Complete dent pulling kit
- | Ideal for small and medium repairs
- | Welding current – 7500 amps
- | Synergic controlled
- | Automatic torch
- | Capacitor discharged



SPEEDLINER ALU

- | Complete dent pulling station
- | Ideal for small, medium and big repairs
- | Welding current – 7500 amps
- | Synergic controlled
- | Automatic torch
- | Capacitor discharged

Paintless Dent Repair System



GYSDUCTION



MAGNETIC ROD TYPE

- | The GYSDUCTION AUTO is a powerful instantaneous induction heater
- | Repairs small dents on the car body without retouching the paint

Plasma cutting equipment



- | Plasma with Inverter technology
- | Cuts up to 10 mm steel, stainless steel and cast iron. Very accurate, the CUTTER 31 FV enables you to cut 0.6mm metal sheets at low intensity without distortion
- | With the "Pilot Arc" system, the arc starts without having any contact with the metallic sheet

MIG Welding Equipment



CARMIG

- | Welding current 15 – 200 A
- | Ideal for welding thin metal sheets
- | Thanks to the SMART chart, find the right settings based on metal thickness and wire type



T 1

- | Welding current 15 – 200 A
- | Ideal for welding thin metal sheets
- | Synergic controlled
- | The machine determines the optimum wire speed by selecting :
 - the type of wire
 - the wire diameter
 - the welding current
- | Recommended for welding steel, stainless steel, aluminum and for MIG brazing of high-tensile strength steels



T 3

- | Welding current 15 – 200 A
- | Three torch supplied as standard scope
- | Synergic controlled
- | The machine determines the optimum wire speed by selecting :
 - the type of wire
 - the wire diameter
 - the welding current
- | Recommended for welding steel, stainless steel, aluminum and for MIG brazing of high-tensile strength steels

Double Pulse MIG Welding Machine for Aluminium



NEOPULSE T3

- | NEOPULSE 270-T2 is a MIG/MAG double pulse accepting SPOOLGUN and PUSH PULL torches
- | TFT display of 5.7 for the best readability: type of wire, gas, current, voltage, thickness, wire speed, welding mode, etc.
- | 2 optical encoders for an easy navigation in different menus.
- | Synergic settings update via SD card.
- | Welding current 15 – 270 A
- | Welding processes : Standard, Pulse,
- | Pulse in Pulse, and Manual.



AUTO PULSE T3

- | AUTOPULSE 320-T3 is a digital MIG/MAG double pulse generator with 3 integrated wire feeders.
- | It is an extremely advanced machine with 46 synergic curves providing an exceptional arc quality
- | Versatile, it will hold 3 different torches to weld steel, aluminium and brazing (CuSi3/CuAl8)
- | Welding processes : Standard, Pulse, Pulse in Pulse, and Manual.
- | Trigger activation modes : 2T, 4T, SPOT, DELAY and TACK function.
- | Precise control over the welding cycle :
 - CreepSpeed, Softstart, Hotstart, Upslope, Downslope, Crater Filler, Postgaz, etc.
- | Welding current 15 – 270 A
- | Synergic controlled
- | Pulse in Pulse welding mode
- | Three torch supplied as standard scope



- | The «Push-Pull» torch has an integrated wire feed motor within the handle
- | Due to its synchronisation with the wire feeder the welding generator the wire speed is extremely smooth / consistent
- | This double action is ideal when the very best results are required when welding small diameter or soft wires which can otherwise be harder to feed smoothly

Transformer Spot Welder - 32 DX



- | Welding current – 10500 A
- | Clamping force – 500 dAN
- | Air Cooled
- | Light weight welding plier – 6 Kg
- | Welding capacity – 3 + 3mm

Inverter Spot Welder - BP.LX



- | Welding current – 13000 A
- | Clamping force – 550 dAN
- | Chemical cooled upto electrode cap
- | Light weight welding plier – 6.5 Kg
- | Single side spot welding plier
- | Dent pulling attachment
- | Welding capacity – 3 + 3 + 3mm
- | Ready for HSS , UHSS , BORON etc

Inverter Spot Welder - BP.LQC



- | Fully Automatic
- | Welding current – 13000 A
- | Clamping force – 550 dAN
- | Chemical cooled upto electrode cap
- | Light weight welding plier – 6.5 Kg
- | Single side spot welding plier
- | Dent pulling attachment
- | Welding capacity – 3 + 3 + 3mm
- | Ready for HSS , UHSS , BORON etc

Inverter Spot Welder - PTI



- | Fully Automatic
- | Inbuilt transformer in plier
- | Welding current – 14500 A
- | Clamping force – 550 dAN
- | Chemical cooled upto electrode cap
- | Light weight welding plier – 10 Kg
- | Cable length – 6 mtr
- | Welding capacity – 3 + 3 + 3mm
- | Ready for HSS , UHSS , BORON etc

Inverter Spot Welder - BP.LCX



- | Fully Automatic
- | 3 Welding plier on the same machine – C , X and Single side
- | Welding current – 13000 A
- | Clamping force – 550 dAN
- | Chemical cooled upto electrode cap
- | Light weight welding plier – 6.5 Kg
- | Single side spot welding plier
- | Dent pulling attachment
- | Welding capacity – 3 + 3 + 3mm
- | Ready for HSS , UHSS , BORON etc

Self Piercing Riveting Equipment TKR PNP 90 XT



- | Compressive force – 10 Ton
- | 2-Circuit-Hydraulic (Push & Pull)
- | Blind riveting attachment upgrade kit available

Self Piercing Riveting Equipment TKR PNP 90



- | Compressive force – 6 Ton
- | Compatible for self-piercing rivets and standard flow form rivets
- | Supplied along with 3 different C arms

Self-piercing Riveting Equipment GYSPRESS 8T



- | Automatic air powered riveter
- | Compatible for self-piercing rivets and standard flow form rivets
- | Maximum pressure of 8 tonnes with integrated pressure gauge
- | Fast and easy arm change
- | C-Arm swivels 360° around the riveting machine axle
- | Selection of arms available for difficult access situations
- | Easy to use ergonomic handle and trigger
- | Magnetic die makes rivet positioning easy

Self Piercing Riveting Equipment AVDEL ESN 50



- | Compressive force – 5 Ton
- | Electro-hydraulic operation

Blind riveting equipment RIVIT 508



- | Pull force – 2.1 Ton
- | Hydro Pneumatic Tool operation

Blind Riveting Equipment Avdel Genesis G4

- | Pull force – 1.9 Ton
- | Hydro Pneumatic Tool operation



Spray Booth 7000 Premium



OBSS 7000 Premium represents a newly developed generation of spraying & drying booths. Whether conventional or water-based paints, OBSS offers optimal conditions for first class spraying results. Most modern technology, new modes of operation and good quality guarantee this. The energy consumption has been minimized – for reasons of costs and for the sake of environment.



High customer utility
Modern technology
Easy handling
High durability
Care of environment

Advantages of VARIO-D Technology

- Air volume adjustment according to the requirement and mode of operation by speed variation
- Reduction of construction elements and thus fewer failure sources
- Precise overpressure regulation by fine adjustment via the motor speed
- Wear-resistant operating
- Considerable saving of heating and electric energy

Water based Paint Curing System - TORNADO

Nozzles designed to deliver more Volume and Velocity to cover the entire profile of the Vehicle



Spray Booth 7000 VD



- | INVERTER TECHNOLOGY – Adjustment of air volumes as required by modification of rotational speed of blowers
- | Considerable saving of electricity by 30% and diesel consumption by 70%
- | Soft start motor reduces the vibration of the Paint Booth by which we are able to restrict the dust level in the Paint Booth to a very large extent
- | Insulated panel of 50mm galvanised and powder coated
- | Roof panel lighting on both sides for painting
- | 3 door design with glass for viewing , lock and handle
- | 1 safety door with pressure lock
- | Roof filter CC-600 grade
- | Floor paint arresting filter
- | Pre filter
- | Down draft blower of European brand - MARZORATI of 24000M3/Hr coupled with 10 HP 3 Phase F class insulation electric motor
- | With Extractor blower
- | Stainless steel heat exchanger
- | REILLO Italian burner with filter and tank HEATING CAPACITY - 2,20,000 K cal/hr

Spray Booth 7000 E

- | Insulated panel of 50mm galvanised and powder coated
- | Roof panel lighting on both sides for painting
- | 3 door design with glass for viewing , lock and handle
- | 1 safety door with pressure lock
- | Roof filter CC-600 grade
- | Floor paint arresting filter
- | Pre filter
- | Down draft blower of European brand - MARZORATI of 24000M3/Hr coupled with 10 HP Phase F class insulation electric motor
- | With Extractor blower
- | Stainless steel heat exchanger
- | REILLO Italian burner with filter and tank HEATING CAPACITY - 2,20,000 K cal/hr



Spray Booth 7000 B



- | Insulated panel of 50mm galvanised and powder coated
- | Roof panel lighting on both sides for painting
- | 3 door design with glass for viewing , lock and handle
- | 1 safety door with pressure lock
- | Roof filter CC-600 grade
- | Floor paint arresting filter
- | Pre filter
- | Down draft blower of European brand - MARZORATI of 24000M3/Hr coupled with 10 HP 3 Phase F class insulation electric motor
- | Stainless steel heat exchanger
- | REILLO Italian burner with filter and tank HEATING CAPACITY - 2,20,000 K cal/hr



- | Dimension 6500 x 3500 mm
- | Metal Basement & Ramp
- | Down draft blower of 24000 M3/Hr Air Volume

Infrared Paint Curing System



IRT 4 -1

Unique possibilities to position the the cassettes

- | Gold-coated FreeForm reflectors for optimal heat distribution
- | Computerized monitoring of curing
- | Pyrometer for exact temperature control
- | Laser circle indicate where temperature measuring takes place
- | Electronic distance sensor
- | Very easy to use
- | Can cure all paint materials
- | Smart stand design
- | Powerful ventilation that cools the cassette and increases lamplife



INFR 3



INFR 2



INFR 1

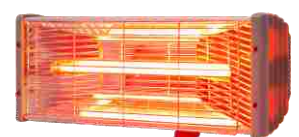

Rapid Spot Paint Explained

SPOT-PAINT is an innovative at-source extraction system developed by OBSS, which allows the paint finishing process to be carried in workshops and other suitable areas, without the need for a conventional spray booth. SPOT-PAINT features a unique hood and masking design. The masking is quickly and easily folded over the hood, creating an enclosure. When the extraction system is switched on, air is funneled into the open aperture, creating a flow of air into the hood. This captures and disperses paint overspray and fumes, protecting the environment.



Why Rapid Spot Paint

- | Eliminates booth dependency for smart repairs.
- | Occupies minimal floor space compared with an extra booth.
- | Cuts out non-productive time masking and moving vehicles.
- | Captures all overspray fumes and particulates.
- | Quick and easy to install.
- | Simple to use.
- | Highly manoeuvrable.



Refinish Equipments and Tools



GTI Pro
Clear coat / Base Coat
Nozzle - 1.2, 1.3 & 1.4mm



SRI Pro
Touch-up
Nozzle - 0.8mm



SLG 600
Primer
Nozzle - 1.8mm



AIR HOSE - 10 Meters



Pressure gauge Analog



Pressure gauge Digital



Dual cartridge respirator



Painter's Overall



Air filter regulator DVFR 1



Air filter regulator DVFR 2



Air filter regulator DVFR 8



Couplers



AIRFED MASK
Full Face



AIR JET GUN



SPRAY GUN CLEANER
MANUAL



SPRAY GUN CLEANER AUTOMATIC
Compatible for Solvent & Water Base Paint

Pneumatic Tools



Air body saw



Rolac Sander



Spot weld drill



Angle grinder



Door hemming tool



Pneumatic surface remover kit



Pneumatic hole punching tool



Door skin removal tool



Belt Sander



Chiesel Hammer Kit



Drilling Machine



Orbital Sander



Vertical Sander



Polisher



Sealant Gun



Impact Wrench



Ratchet Wrench

Color Match Light



Dust- Free Sanding System

Air operated
Maintenance free
Completely noiseless



Plastic Repair Kit

Model : Hot Stapler

Model : Brazing

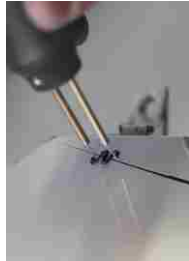

Windshield Cutting Kit

Windshield Joint - Cutting Kit

Suction Cup set With Strap



Pneumatic Windshield Removal Kit



Professional Windshield Repair System



Bodyshop Hand Tools



Hammer and Dolly Set



Vice Grip PlierSet

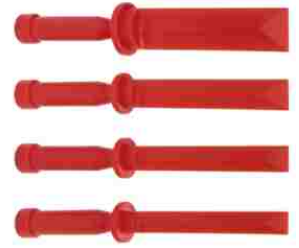

Nylon ChieselSet



Contour Gauge



Sliding Hammer Set

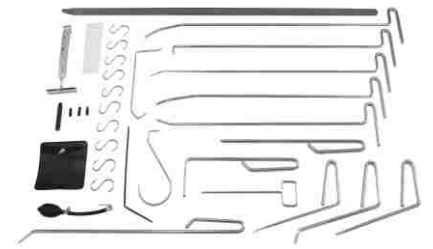

Paintless Dent Repair Kit



Safety Goggles



Grinding Helmet



Auto Darkening Welding Helmet



Auto Darkening Welding Helmet Premium



Grinding Protection Sheet



Welding Protection Sheet



Magnet for Sheet



Welding Curtain



Welding Gloves



Welding Gloves Premium



Anti Cut protection gloves



Welding Protection Sleeves



Welding Protection Apron

Hydraulic Body Repair Kit - 10 Ton
Professional Series



Body Chisel

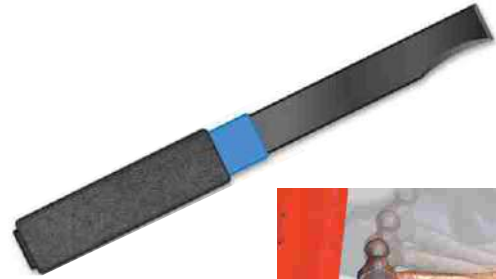

For quarter panels, rockers and any other pinchweld Sharpened on two edges allowing for penetration between panels and the side edge allows for side impact to drive the panels apart without damage Super tough alloy steel Cushioned handle absorbs shock.

Electro-power Push & Pull
Body Jack 5 Ton



- | The only existing Pushing and Pulling System
- | Electric Battery 14.4V Operated
- | Pulling Power - 5 Ton
- | Pushing Power - 5 Ton
- | Piston Stroke - 130 mm



Induction Heating Equipment



Hand-Duction

- | Designed to heat and remove any mechanical part in a few seconds e.g. seized bolts/nuts, screws..etc.
- | Light, it weighs only 2.54 kg
- | 1000 W power
- | Immediate heating without flame on a specific area!



GYS Duction



- | The GYSDUCTION AUTO is a powerful instantaneous induction heater.
- | Remove all adhesives, logos, side moldings.
- | Remove direct glazed windows without damaging the trim (rear window, rear quarter light, panoramic roof)
- | Remove stone guard protection and sealers.
- | Release mechanical parts (bolts, screws, spark plug, injector).
- | Repair small dents on the car body without retouching the paint.

Powerduction



POWERDUCTION 37LG

- | Provides instant and powerful heating to release, or simply heat, steel or aluminium
- | Power – 3700 W
- | Water cooling system
- | Essential to release steering linkage (wheel alignment).
- | Removal of glow plugs, seized up wipers, spare wheel crates.
- | Releasing of seized up bolts.
- | Releasing of steering ball joints without damaging the bellow.
- | Releasing of shaft drives seized up in the hub.
- | Removal of automotive or truck exhaust lines.
- | Removal of steel or aluminium elements assembled with glue.



POWERDUCTION 50LG

- | Provides instant and powerful heating to release, or simply heat, steel or aluminium.
- | Equipped with a liquid cooling unit
- | Power -5200 W
- | Essential to release steering linkage (wheel alignment).
- | Removal of glow plugs, seized up wipers, spare wheel crates.
- | Releasing of seized up bolts, releasing of steering ball joints without damaging the bellow.
- | Releasing of shaft drives seized up in the hub.
- | Removal of automotive or truck exhaust lines.

Bodyshop Stands



Trestle



Windscreen Stand



Bumper Repair Stand



Universal Swivel Stand



Masking Paper Trolley
Premium



Masking Paper Trolley



Bodyshop Removed
Parts Trolley



Folding Step Stool



Mechanic Creeper

Tools Board



SPECIAL TOOLS STORAGE PANEL



WALL MOUNTED



TROLLEY TYPE

HESHBON
Two Post Lift – HL 27M



- | Lifting Capacity – 6 Ton
- | Electro hydraulic mechanism
- | Clear floor model
- | RAM type cylinders provide powerful and safe lifting performance
- | Double telescopic pad screws

HESHBON
Two Post Lift – HL 26K



- | Lifting Capacity – 4 Ton
- | Electro hydraulic mechanism
- | Clear floor model
- | RAM type cylinders provide powerful and safe lifting performance
- | Double telescopic pad screws

OBSS Pro
Two Post Lift – 2PL4AS



- | Lifting Capacity – 4 Ton
- | Electro hydraulic mechanism
- | Clear floor model
- | RAM type cylinders provide powerful and safe lifting performance
- | 250mm height adjustable extension post connection according to the height of workshop ceiling
- | Roof top protection limit sensor touch bar
- | High quality pre-stretched synchronization wire rope
- | Double telescopic pad screws

HESHBON Interactive Bay Scissor Lift – HL 35F



- | Master and Slave cylinder system
- | Air operated locking device
- | Easy synchronization control system
- | Lifting Capacity – 4000 Kg

- | Ultra-thin low profile platform can be mounted on the ground
- | Platform length can be extended to 2000n compatible for even SUVs
- | Auto synchronization control system
- | Lifting capacity – 3.5 Ton

OBSS Pro Interactive Bay Scissor Lift - IBL-DS 350N



OBSS Pro Interactive Bay Scissor Lift - IBL-DS 42IN



- | Floor recess mounted model
- | Mechanical safety lock, explosion-proof valves and self-lock hydraulic system ensure safety to technician
- | Platform can be extended for accommodating long chassis vehicles
- | Auto synchronization control system



OBSS Pro
Four Post Lift - 4PL4 - 1CJ



- | Hydraulic cylinder located in the fixed platform and is thus perfectly protected
- | High resistance galvanized and pre-stretched lifting cable
- | Lock release lever for the emergency situation
- | Self lubricated large diameter pulleys and maintenance-free bushes
- | Hydraulic two-level 2 Ton scissor jack
- | Lifting Capacity – 4 Ton

HESBON
Wheel Alignment Scissor Lift - HL 53X

- | Master and Slave cylinder system
- | With 2 Nos Centre Jack
- | Air operated locking device
- | Easy synchronization control system
- | Front turn-table recess and rear sliding plates
- | Applicable for both in/above ground mount
- | Lifting Capacity – 4000 Kg



OBSS Pro
Wheel Alignment Scissor Lift - WASL4 - 1CJ

- | Super low profile platform (165mm minimum height)
- | Auto synchronization control system
- | Secondary lifting trolley is controlled by both manual button and remote
- | Mechanical safety lock, explosion- proof valves and self-lock of hydraulic systems ensure safety to the technician



Spot Lift

Wheel Lift Trolley



Lifting Capacity – 2.5 Ton (Vehicle)
Max Lifting Height – 700mm
Wheel and Rocker panel lifting attachment



Hydraulic Press
Capacity 10 Ton / 20 Ton



Hydraulic Engine Crane
Capacity 1 Ton / 2 Ton



Hydraulic Transmission Jack
Capacity 0.5 Ton / 1 Ton / 1.5 Ton



Go - Jack



Engine Stand



Hydraulic Trolley Jack
Capacity 3 Ton

Diagnostic Smoke Vapor Machine



- | New generation (G3) automotive diagnostic smoke machine
- | Test Natural Vacuum EVAP Systems
- | Easy to Read Flow Control Knob Position
- | Vacuum and Pressure Decay Gauge
- | Find Leaks Using Smoke and UV Dye

Endoscope

- | 4 high brightness LEDs
- | High resolution 720 x 625 pixels
- | Optimal distance fixer
- | Glare-free close-up viewing field
- | 5.5mm side view camera
- | Waterproof IP67

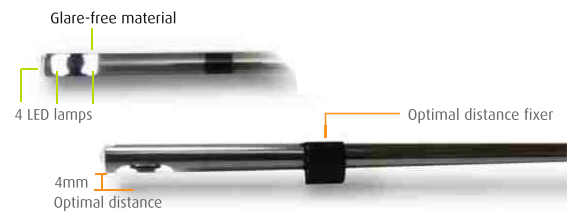

AC Recovery & Recycling Machine



Fully Automatic
R134a



Fully Automatic
R134a



Fully Automatic
R1234yf

AC Leak Detector



Ozone Generator



Head Light Beam Aligner



Battery Chargers



Charging Current – 7 amps
Automatic model



WATTMATIC 170
Charging Current – 10 amps



CA 360
Charging Current – 25 amps
Automatic model



GYS FLASH 30.12
Charging Current – 30 amps
Automatic model



GYS FLASH 50.12
Charging Current – 50 amps
Automatic model



GYS FLASH 100.12
Charging Current – 100 amps
Automatic model

Battery Tester



BT 282DHC



BT 551 with Printer



BT 2010 with Printer

Battery Booster



GYSPACK PRO



STARTRONIC 800
Battery Less Technology



NOMAD POWER PRO 90
Lithium on Battery

Tyre Inflation Equipment



TYRE INFLATOR - NITROGEN

- | CONSISTENT NITROGEN PURITY – 97-99.9%
- | DUAL POWER – ELECTRICITY AND BATTERY
- | DUAL MEDIUM – AIR AND NITROGEN
- | FASTER INFLATION – 28 sec (0-60psi)
- | AUTOMATIC – VACUMIZER , INFLATION AND NITROGEN GENERATION
- | COMPACT DESIGN AND ON WHEELS FOR EASY HANDLING

TYRE INFLATOR – WALL MOUNTED



- | Bright, superior, long-life LED display
- | 45mm digits visible from a long distance (as compared to normal 25mm)
- | Compact Design
- | Faster Inflation
- | Membrane switches and Rain proof IP 65
- | Polycarbonate enclosure

TYRE INFLATOR - PEDESTAL

- | Auto start inflation
- | Automatic zero drift adjustment
- | Large backlight LED display
- | Audible & visual end of cycle signal indicator
- | Two wheeler / four wheeler mode for faster and accurate inflation



Fluid Management Equipment

Brake Bleeding Equipment
PREFECTA 20MB



Automatic Transmission
Fluid Exchanger



Fuel Retriever



WASTE OIL
DRAINER



Vehicle Exhaust Extraction System

Motor Driven & Automatic Damper Hose Reel



Manual Spring Recoil



Rail Type



Rail Trolley Type



Direct Extractor



Nozzles



Nozzle for Hidden Exhaust Pipe



Nozzle for Dual Exhaust Pipe



Handle Nozzle



Nozzle for Truck & Bus

Welding Fume Extraction Portable Model



- | Designed to extract and purify dry fumes generated by various welding processes
- | Three filtration process - Metal filter, Absolute filter and Coal filter
- | Automatic extract from welding start.
- | Automatic fan stop about 50 s. after turning off the welding machine

Tools & Accessories



Measuring instruments



Torque wrenches



Hose clamp plier

Battery Fluid Tester

Clip Remover

Ball Joint Separator

Preset oil dispensing gun



Tube Cutter and Flaring Tool



Sliding Hammer Set



Mac Pherson Spring Compressor

Tool Kit

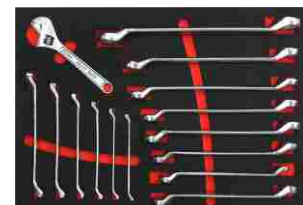
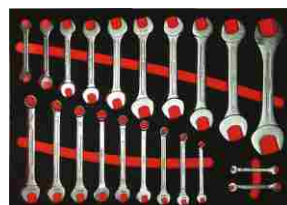
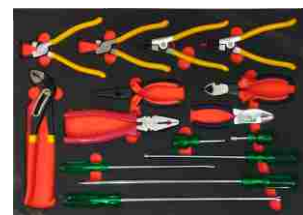
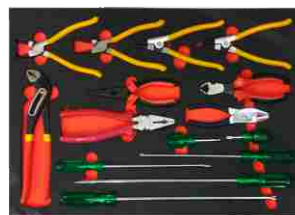

Express Trolley



Express Bay Trolley
With Wheel Lift



Express Bay Trolley
Premium



Express Bay Trolley
Eco

Tools Trolley



OTTM-3



OTTM-5



OTTM-7

Work Bench



KWB



OWBDX



OWBTVS

The logo for OBSS, featuring the letters 'OBSS' in a bold, blue, sans-serif font with a white outline.

Orient **Bodyshop Solutions India P Ltd.,**

Corporate Office : No. 266 | Dr.Nanjappa Road | Coimbatore - 641 018 | Tamil Nadu | India.

Training Center : 796/1A | Avinashi Road | Neelambur | Coimbatore - 641 062 | Tamil Nadu | India.

Mobile : +91 95436 70077 | **E-Mail :** ali.imani@obss.in